



IFB NO. 24-047

INVITATION FOR BID

FOR

Bus Stop Improvements Construction Group A-1

September 18, 2024

Table of Contents

SECTION 1. INTRODUCTION..... 3

1.1 STATEMENT OF INTENT 3

1.2 BACKGROUND..... 3

1.3 PRE-PROPOSAL MEETING 3

1.4 DISADVANTAGED BUSINESS ENTERPRISES..... 3

1.5 PERMITS 4

1.6 USE OF BRAND OR TRADE NAMES 4

1.7 GOTRIANGLE PROJECT CONTACTS..... 4

SECTION 2. SCOPE OF WORK 5

2.1 SCOPE AND SERVICES TO BE PERFORMED 5

2.2 PERIOD OF PERFORMANCE..... 5

2.3 BID DOCUMENT ATTACHMENTS..... 5

SECTION 3. BID REQUIREMENTS 6

3.1 INFORMATION REQUIRED FROM THE CONTRACTOR 6

3.2 GENERAL BID REQUIREMENTS 7

3.3 CHANGES TO IFB DOCUMENT(ADDENDA) 8

3.4 QUESTIONS 8

3.5 BID OPENING 8

3.6 EXAMINATION OF BIDS AND DETERMINATION OF RESPONSIVENESS 9

SECTION 4. AWARD CRITERIA..... 9

4.1 SELECTION 9

4.2 SELECTION PROCESS PROTEST PROCEDURES 9

4.3 ACCEPTANCE OR REJECTION OF BIDS..... 10

4.4 SCHEDULE OF EVENTS 11

SECTION 5. GENERAL BID CONDITIONS..... 12

5.1 NOTICE OF FORMAL SOLICITATION 12

5.2 METHOD OF RESPONSE 12

5.3 ACCEPTANCE OF TERMS AND CONDITIONS 12

5.4 FALSE, INCOMPLETE OR UNRESPONSIVE STATEMENTS 12

5.5 CLEAR AND CONCISE SUBMISSION 12

5.6 PRIME CONTRACTOR RESPONSIBILITIES 12

SECTION 6. ATTACHMENTS..... 13

INVITATION FOR BID

FOR

Construction Group A-1

SECTION 1. INTRODUCTION

1.1 STATEMENT OF INTENT

Research Triangle Regional Transportation Authority D/B/A GoTriangle ("GoTriangle") invites qualified and experienced firms with recent and relevant experience to submit Bids for consideration to contract with GoTriangle to provide **Bus Stop Improvements Construction Group A-1** as set forth in this solicitation. Firms may express interest and request consideration by submitting bid material to GoTriangle as set forth in this Invitation for Bid.

To obtain a copy of the Invitation for Bid (IFB) document, Contractors shall download the document from the GoTriangle's website at <https://gotriangle.org>.

Bids will be received until 10:00 a.m. on Wednesday **October 10, 2024 (EST)** on at GoTriangle's Administrative Office located at 4600 Emperor Blvd., Suite 100, Durham, North Carolina, 27703. Questions regarding the Bids shall be directed to William Bryant, Interim Procurement Manager at wbryant@gotriangle.org. GoTriangle reserves the right to reject any or all Bids.

Bids are due by 10:00 am. Bids will be opened virtually via MS Teams at 11:00 am.

1.2 BACKGROUND

Bidder hereby proposes to furnish all materials, tools, machinery, equipment, apparatus, labor, and all means necessary to perform all tasks detailed in the Scope of Work.

1.3 PRE-PROPOSAL MEETING

A Non-mandatory Pre-Bid Conference will be held, via **Microsoft Teams Meeting at 9:00 a.m. on Tuesday September 24, 2024.** The meeting information is listed below. The purpose of this meeting is to offer an opportunity for prospective bidders to familiarize themselves with the site and ask questions pertaining to the project and Contract Documents.

Microsoft Teams meeting

[Join the meeting now](#)

Meeting ID: 229 539 654 59

Passcode: HFfi9n

Dial in by phone

[+1 252-210-4099,,584581424#](#) United States, Rocky Mount

[Find a local number](#)

Phone conference ID: 584 581 424#

DISADVANTAGED BUSINESS ENTERPRISES

Pursuant to 49 C.F.R. Part 26, GoTriangle has established a Disadvantaged Business Enterprise (DBE) Program that states “GoTriangle shall not discriminate in any manner on the basis of race, color, sex or national origin, and shall take all reasonable steps to ensure that certified Disadvantaged Business Enterprises have the maximum opportunity to participate in the performance of contracts.

In conformity with North Carolina State law, it is the policy of GoTriangle to encourage and promote the use of minority contractors, physically handicapped contractors, and women contractors in the purchasing of goods and the provision of services. Proposers are encouraged to utilize minority, handicapped and women-owned businesses to the extent possible when assembling its team.

Jamila Ormond, GoTriangle Director of Equal Opportunity Employment/Disadvantaged Business Enterprises may be reached at 919-485-7518 or jormond@GoTriangle.org with questions about GoTriangle’s DBE Program. **This project has a 27% DBE Goal.**

1.4 PERMITS

The Contractor is responsible to obtain, at their expense, any permits, certifications and/or licenses to complete the construction project. Copies of all inspections and permits shall be given to GoTriangle for record keeping. All work must comply with all safety, electrical, and building codes of the State of North Carolina and local ordinances.

1.5 USE OF BRAND OR TRADE NAMES

The use of brand names, trade names, types, styles, model numbers and serial numbers are intended to be descriptive only and not intended to restrict competition. Specific brand names will be used as a comparative measure of the safety, quality and performance against all Bid submissions. However, other brand names, types, styles, model numbers have to be “equal” and meet the minimum requirements of the OEM.

1.6 GOTRIANGLE PROJECT CONTACTS

Unless otherwise notified:

1. **Pre-Award Contact:** Prior to contract award all questions, comments, correspondence and Bid packages shall be transmitted to the attention of the following individual, serving as the Owner’s Representative during Pre-Award:

William Bryant, Procurement Administrator

Office: 919-485-7429

wbryant@gotriangle.org

2. **Post-Award Contact:** After the contract is awarded, the contractor and subcontractors shall transmit all project related questions, correspondence and other communications to the attention of the following individual, serving as the Owner’s Representative during Post-Award:

Senior Engineer Design, GoTriangle

Bong Vang

Office: 919-485-7557

bvang@gotriangle.org

SECTION 2. SCOPE OF WORK

2.1 SCOPE AND SERVICES TO BE PERFORMED

Attached are plans and specification to provide all labor, materials, equipment and supplies to complete tasks related to the bus stop amenity improvements located at various locations in Durham , North Carolina.

2.2 PERIOD OF PERFORMANCE

Contractor has 90 (ninety) calendar days from the date of Notice to Proceed to the final closeout and Owner acceptance of the project for the base bid.

2.3 BID DOCUMENT ATTACHMENTS

- 1 Exhibit A Construction Group A-1 Drawings.pdf
- 2 Exhibit B Construction Group A-1 Technical Specifications

END OF SPECIFICATIONS

SECTION 3. BID REQUIREMENTS

3.1 INFORMATION REQUIRED FROM THE CONTRACTOR

Contractor's submission must include all of the following:

- 3.1.1** Signed and completed Bid Form (Attachment A)
- 3.1.2** Signed and completed Price Sheet (Attachment B) in **sealed envelope**
- 3.1.3** A 5% bid bond or certified check must accompany your Bid if Bid price is over \$100,000.00.
- 3.1.4** Project Personnel: Identify key Construction Project Manager.
- 3.1.5** Key Point of Contact: List main point of contact and/or Project Manager.
- 3.1.6** Schedule and Work Plan: Develop a Project Management schedule that shall include all of the construction work activities. Indicate the time-frame for accomplishing the work.
- 3.1.7** Subcontractors: Provide a listing of the subcontractors' names, address and role in this contract.
- 3.1.8** Copy of State of North Carolina General Contractor's License
- 3.1.9** Proof of insurance as required and listed in (Attachment C)
- 3.1.10** E-Verify (Attachment D)
- 3.1.11** Contractor's Statement of Sales/Use Tax (Attachment E)
- 3.1.12** Iran Divestment Certificate (Attachment F)
- 3.1.13** Companies Boycotting Israel Divestment Act Certificate Form (Attachment G)
- 3.1.14** Certificate Regarding Conflict of Interest (Attachment H)
- 3.1.15** Non-Collusion (Attachment I)
- 3.1.16** Davis – Bacon Rate Forms (Attachment J)
- 3.1.17** M/WBE Forms (Attachment K)
- 3.1.18** Responsive Checklist (Attachment L)
- 3.1.19** *Contractor shall provide within 5 calendar days from notice of award the following bonds if Bid price is over \$100,000.00:*
 - Time and Material Payment Bond – 100% of the contract price
 - Performance Bond – 100% of contract price

3.2 GENERAL BID REQUIREMENTS

For a Bid to be considered, all documents required by this IFB must be submitted in the specified format. The Bid submission should follow the format and order set forth in Section 3.1 above. Submit one (1) original and three (3) additional copies of the Bid, and one USB Flash Drive. All Bids become the property of GoTriangle. GoTriangle will not photocopy your Bid documents for the purpose of complying with this provision requiring duplicate copies. Failure to provide the required number of complete duplicate copies may result in rejection of your Bid. GoTriangle will receive Bids only by personal delivery, courier/delivery service, or regular mail. Bids submitted by facsimile or email will not be accepted. **Bids will be received until 10:00 a.m. and opened at 11:00 a.m. by way of Microsoft Teams:**

Microsoft Teams meeting

[Join the meeting now](#)

Meeting ID: 261 258 690 712

Passcode: kDfbXX

Dial in by phone

[+1 252-210-4099,,249442723#](#) United States, Rocky Mount

[Find a local number](#)

Phone conference ID: 249 442 723#

For organizers: [Meeting options](#) | [Reset dial-in PIN](#)

The Bid must be submitted to Mr. William Bryant, Procurement Administrator by the time and date indicated above, marked **“IFB 24-047 Bus Stop Improvements Construction Group A-1”**.

Please acknowledge receipt of any addendum received on bid form.

Please note the different remit to addresses below, if Contractor chooses to send the Bid by personal delivery, courier/delivery service, or by US mail:

	Delivered By Personal Delivery or Courier/Delivery Service
	GoTriangle 4600 Emperor Blvd Durham, NC 27703

NO BIDS RECEIVED AFTER THE DATE AND HOUR SET FORTH BELOW WILL BE ACCEPTED OR CONSIDERED. BIDS SENT BY U.S. MAIL THAT ARE NOT RECEIVED IN HAND BY GOTRIANGLE BY THE DEADLINE SET FORTH BELOW WILL NOT BE CONSIDERED.

There will be a **public bid opening (via Microsoft Teams at 11:00 a.m.)**. IFBs are being solicited under the GoTriangle purchasing policy for “Informal Bids”. “Informal Bids” are kept confidential until a Contract has been awarded. There is no expressed or implied obligation for GoTriangle to reimburse Contractors for any expenses incurred in preparing Bids in response to this IFB

The awarding of the Contract, if awarded, will be made by GoTriangle as soon thereafter as practicable. Contractors not chosen will be notified in electronic correspondence. The Bid Form should be signed by a responsible representative of the company submitting the Bid. Bid Forms that are not signed will not be considered.

3.3 CHANGES TO IFB DOCUMENT(ADDENDA)

Any changes to this IFB document will be made by written addenda issued by GoTriangle. Upon issuance, the addenda will be considered part of the IFB document and will prevail over inconsistent or conflicting provisions contained in the original IFB document. Addenda will be sent electronically via email from the Procurement Administrator. This process will be repeated each time an addendum is posted to the GoTriangle website.

A valid e-mail address must be provided upon requesting the IFB documents in order for GoTriangle to notify Contractors of the availability of addenda. GoTriangle will not be responsible for Contractors failing to receive notification of the availability of addenda if an invalid e-mail address or no e-mail address was provided to GoTriangle.

Contractors shall acknowledge their receipt of all addenda in Bid Form (Attachment B) submitted with their Bid submission. As with other required documentation, Bids that fail to provide a detailed listing of addenda received may be excluded from further consideration for this solicitation.

A revised due date of Contractor’s Bid (if applicable) shall be stated in each addendum. If you have received this solicitation from a source other than the GoTriangle, it is the Contractor’s responsibility to ensure that all addenda have been received.

3.4 QUESTIONS

Any questions regarding this IFB should be directed to William Bryant, Interim Procurement Manager. All questions must be submitted in writing before 5:00 p.m. EDST September 26, 2024. Questions will be emailed only to William Bryant at wbryant@gotriangle.org. Responses to questions will be posted on the GoTriangle’s website (<https://gotriangle.org/invitation-bids-afb>) by 5:00 p.m. EDST on September 27, 2024. All Contractors that have requested previously IFB documents from the GoTriangle website shall be notified of responses via e-mail.

3.5 BID OPENING

GoTriangle Procurement Administrator will open the bids in the presence of bidders’ designated representatives who choose to attend, at the time, date and location stipulated in the Bidding Document. The bidders’ representatives who are present, shall sign a register evidencing their attendance. Bids not opened and read out at bid opening shall not be considered further for evaluation, irrespective of the circumstances. The Employer shall prepare minutes of the bid opening including the information disclosed to those present.

3.6 EXAMINATION OF BIDS AND DETERMINATION OF RESPONSIVENESS

Information relating to examination, clarification, evaluation and comparison of bids and recommendations for the award of a contract shall not be disclosed to bidders or any other persons, not initially concerned with such process until the award to the successful bidder has been announced. Any effort by a bidder to influence the processing of bids or award decisions may result in the rejection of the bidder's bid.

A substantially responsive bid is one that conforms to all the terms and conditions and specifications of the bidding document without material deviation or reservation. A material deviation or reservation is one which affects in any substantial way the scope, quality, or performance of the work and which limits in any substantial way. Inconsistent with the bidding documents, GoTriangle's rights or the bidder's obligations under the contract, or whose Rectification would affect unfairly the competitive position of other bidders presenting substantially responsive bids.

If a bid is not substantially responsive, it will be rejected by GoTriangle and may not subsequently be made responsive by correction or withdrawal and the non-conforming deviations or reservations.

SECTION 4. AWARD CRITERIA

4.1 SELECTION

Bids will first be reviewed for responsiveness and inclusion of the components specified in **Section 3** for this IFB document. The absence of any required information may result in exclusion from further analysis.

GoTriangle will make the award to the lowest responsive responsible Contractor whose Bid is most advantageous to the GoTriangle.

GoTriangle may waive any irregularities in any Bid that does not prejudice other Contractors. GoTriangle further reserves the right to negotiate when bids exceed budget amount.

4.2 SELECTION PROCESS PROTEST PROCEDURES

Protests made with respect to this IFB shall be submitted to the CEO not later than five (5) business days after the recommendation of award has been announced. The CEO shall provide a written response within but not later than five (5) business days after receiving such protest. GoTriangle's written response and disposition of protest findings shall be deemed final. GoTriangle's CEO shall report all such protests to the Board of Trustees prior to a Contract award.

Any and all protests filed with GoTriangle CEO shall be submitted in writing and:

- a) Include the name and address of the protester.
- b) Identify the procurement by solicitation number and then the current deadline date for receipt of Bids.
- c) Contain a statement of the legal and factual grounds for the protest and any supporting documentation. The grounds for the protest must be fully supported.
- d) Indicate the ruling or relief that protester desires from GoTriangle.

Violations of federal law or regulations will be handled by the complaint process stated within that law or regulation. Violations of state or local law or regulations will be under the jurisdiction of state or local authorities.

4.3 ACCEPTANCE OR REJECTION OF BIDS

Failure to respond to any of the requirements outlined in either the Invitation for Bids or the Bid Form or a failure to enclose or submit any of the required documents may disqualify the Contractor's Bid submission.

GoTriangle has the sole right to select the successful Contractor for award; to reject any and all IFBs and to re-solicit for new IFBs.

IFBs shall be submitted to GoTriangle on the most favorable of terms possible from the standpoint of cost, quality, delivery date and technical capability. No Contractor shall have any cause of action against GoTriangle arising out of the methods by which IFBs are assessed. The selection of the successful Contractor shall be at the sole discretion of GoTriangle.

Submission of a Bid indicates acceptance by the Contractor of the conditions contained in this IFB unless clearly and specifically noted in the Bid submitted and confirmed in the Contract between GoTriangle and the selected Contractor.

4.4 SCHEDULE OF EVENTS

DATE	IFB N0: 24-047 Construction Group A
September 18, 2024	IFB distributed and posted to GoTriangle website
September 24, 2024	Non-Mandatory Pre-Proposal Conference via teleconference
September 26, 2024	Inquires must be received in writing by (e-mail Only) to wbrvant@gotriangle.org
September 27, 2024	Responses to all questions received will be posted on the GoTriangle website. All firms that have previously registered and downloaded the IFB documents from the GoTriangle website will be notified of responses via e-mail.
October 10, 2024	Bids are due. There will be a public bid opening by way Microsoft Teams at 11:00 am.
October 18, 2024	Bids Evaluated
TBD	Review and Selection Committee recommends award to the CEO & President
October 25, 2024	Issue Notice of Intent to Award
TBD	GoTriangle Board of Trustees authorizes the CEO to execute contract with the recommended Submitter.
TBD	Enter into Contract with Awarded Firm

SECTION 5. GENERAL BID CONDITIONS

5.1 NOTICE OF FORMAL SOLICITATION

Notwithstanding any other provision of this IFB, all Contractors are hereby specifically advised that this IFB is a form solicitation for Bids only, and is not intended and it not to be constructed as an offer to enter into an agreement or engage into any formal competitive bidding or negotiation pursuant to any statute, ordinance, rule of regulation.

5.2 METHOD OF RESPONSE

Responses to this IFB shall be made according to the scope of work and instructions contained herein. Failure to adhere to instructions may be cause for rejection of any Bid.

5.3 ACCEPTANCE OF TERMS AND CONDITIONS

Contractors understand and agree that submission of a Bid will constitute acknowledgment and acceptance of, and a willingness to comply with, all the terms, conditions, and criteria contained in this IFB, except as otherwise specified in the Bid. Any and all parts of the submitted Bids may become part of any subsequent Agreement between the selected Contractor and GoTriangle.

5.4 FALSE, INCOMPLETE OR UNRESPONSIVE STATEMENTS

False, incomplete, or unresponsive statements in connection with a Bid may be sufficient cause for rejection of the Bid. The evaluation and determination of the fulfillment of the above requirement will be GoTriangle's responsibility and its judgment shall be final.

5.5 CLEAR AND CONCISE SUBMISSION

Bids shall provide a straightforward, concise delineation of the Contractor's capability to satisfy the requirements of the IFB. Each Bid shall be submitted in the requested format and provide all required information. **Each Bid shall be signed in ink by a duly authorized officer of the company.**

5.6 PRIME CONTRACTOR RESPONSIBILITIES

The selected Contractor will be required to assume responsibility for all requested deliverables as indicated in Section 2 regardless of who produces them. Further, GoTriangle will consider the selected Prime Contractor to be the sole point of contact with regard to contractual matters, including payment of any and all charges resulting from the contract. Contractor and/or subcontractor shall give a copy of their State of North Carolina Contractor License and permits from governmental agencies as required upon notification of award. The Prime Contractor agrees to pay each Subcontractor under this prime contract for satisfactory performance of its contract no later than 30 days from the receipt of each payment the Prime Contractor receives from GoTriangle. Any delay or postponement of payment from the above referenced time frame may occur only for good cause following written approval of GoTriangle. The clause applies to both DBE and non-DBE subcontracts.

Retainage:

The Prime Contractor agrees to return retainage payments to each subcontractor within 30 days after the Subcontractors work is satisfactory completed. Any delay or postponement of payment from the above referenced time frame may occur only for good cause following written approval of GoTriangle. This clause applies to both DBE and non-DBE subcontracts.

SECTION 6. ATTACHMENTS

PLEASE REFER TO THE FOLLOWING ATTACHMENTS:

Attachment A – Vendor Information Form

Attachment B – Bid Price Form

Attachment C – Minimum Insurance Requirement

Attachment D – E-Verify Form

Attachment E – Contractor’s Statement of Sales/Use Tax

Attachment F – Iran Divestment Act Certificate

Attachment G – Companies Boycotting Israel Divestment ACT Certification Form

Attachment H – Certificate Regarding Conflict of Interest

Attachment I – Non-Collusion

Attachment J – Davis-Bacon Rate Forms

Attachment K- M/WBE Forms

Attachment L – RFP Responses Checklist

Attachment – Bid Exhibit Documents

A. Exhibit A Construction Group A-1 Base Bid Plans

B. Exhibit B – Construction Group A-1 Technical Specifications

Attachment-A

SUBMITTAL FORM PROPOSER INFORMATION AND SIGNATURE

Firm's Legal Name/Address: _____ Date Prepared: _____

_____ Date Firm Established: _____

_____ Principal to Contact/Title: _____

_____ Business Telephone: _____

_____ Business Email: _____

Is this address the: Main Office Regional Office Branch Office Other _____

Former Firm Name(s), if any. **Year Established** **Name/Address/Telephone of Parent Company, if any**

Corporate Structure:

Sole Proprietorship Corporation Joint Venture
 Parent Company Partnership Other (specify): _____

Other offices of the firm:

City/State **Telephone No.** **No. of personnel** **Identify home office with ***

1. State of Incorporation: _____
2. State of North Carolina Registration #: _____
3. Federal Tax Identification #: _____
4. Acknowledge Addendum(a) by specifying Addendum(a) in spaces provided: _____

Certification

The undersigned prime proposer certifies that, to the best of his/her knowledge, the information presented in this Request for Proposals is a statement of facts and that the firm has the financial capability to perform the work being applied for. The undersigned prime proposer further certifies that it knows of no personal and/or organizational conflict of interest prohibited under federal, state, and local law.

I certify (or declare) under penalty of perjury under the laws of the State of North Carolina that the foregoing is true and correct.

Name: _____

Signature: _____

Title: _____

Date: _____

Place: _____

(City and State)

END OF FORM

ITEMIZED PROPOSAL / SCHEDULE OF PRICES - BASE BID

GoTriangle Bus Stop Improvements - #A-1

Addition of bus stop and site amenities to bus stop locations generally consisting of grading, concrete pads and sidewalks, installing amenities, and other related items.

= FILL OUT INFORMATION FOR UNIT BID AND AMOUNT BID

= NOT APPLICABLE FOR SECTION

Item No.	Item Description	Unit	Quantity	Unit Bid Price	Amount Bid
1	MOBILIZATION/TRAVEL TIME	LS	1		
2	DEMOLITION	LS	1		
3	EARTHWORK	LS	1		
4	EROSION CONTROL	LS	1		
5	TEMPORARY TRAFFIC CONTROL	LS	1		
6	THERMOPLASTIC PVT MKG LINES (24", 90 MILS)	LF	217		
7	THERMOPLASTIC PVT MKG LINES (6", 90 MIL)	LF	320		
8	THERMOPLASTIC PVT MKG LINES (12", 90 MIL)	LF	68		
9	THERMOPLASTIC PVT SYMBOL, 90 MILS	EA	4		
10	THERMOPLASTIC PVT MKG CHARACTER, 90 MILS	EA	13		
11	GREEN PAINT	SF	1789		
12	GRASS SOD / MULCH	SF	3146		
13	ASPHALT PAVEMENT REPAIR PATCH	TON	2		
14	ASPHALT PAVEMENT - ASP CONC SURF CRS S9.5B	TON	6		
15	ASPHALT PAVEMENT - ASP CONC INTR CRS	TON	8		
16	ASPHALT PAVEMENT - ASP CONC BASE CRS B25.0C	TON	27		
17	4" CONCRETE SIDEWALK	SF	1182		
18	6" CONCRETE SIDEWALK	SF	531		
19	6" CONCRETE PAD	SF	2742		
20	2'-6" CURB & GUTTER	LF	140		
21	SURFACE MOUNTED CONCRETE CURB	LF	96		
22	CONCRETE CURB RAMP	EA	7		
23	MODULAR RETAINING WALL	SF	123		
24	INSTALL SHELTER AND AMENITIES	EA	3		
25	INSTALL BENCH AND AMENITIES	EA	8		
26	INSTALL BIKE RACK	EA	6		
27	INSTALL BUS STOP SECURITY LIGHTING SYSTEM	EA	12		
28	RELOCATE SIGN	EA	12		
29	PERMANENT SIGNAGE	EA	3		
30	ADJUST UTILITY BOX/VAULT	EA	2		
31	12" RCP PIPE	LF	12		
32	MASONRY DRAINAGE STRUCTURE - STORM INLET - DURHAM STD 633.03	EA	1		
33	FLOWABLE FILL	CY	9		
	BASE BID SUBTOTAL				
	10% CONTINGENCY OF BASE BID SUBTOTAL				
	BASE BID TOTAL				

NOTE: ALL UNIT PRICES, EXTENSIONS, AND TOTAL BID AMOUNTS ARE MANDATORY. OMISSION OF ANY PRICES, EXTENSIONS, OR TOTAL BID AMOUNTS SHALL RESULT IN THE REJECTION OF THE BID. UNIT PRICES FOR ADD ALTERNATE ITEMS SHALL BE THE SAME AS THOSE LISTED ON THE BASE BID, EXCEPT FOR ITEMS TO PAID BY LUMP SUM. THE UNIT PRICES FOR THE ITEMS IN THE CONTRACT ARE FOR FURNISHING, INSTALLING, COMPLETING, HAVING IN PLACE, AND BEING ACCEPTED.

Attachment C to GoTriangle Contract No. 24-047
Minimum Insurance Requirements

1. Definitions. “Contractor” as used in this Exhibit shall mean: _____ “GoTriangle” as used in this Exhibit shall mean the Research Triangle Regional Public Transportation Authority dba GoTriangle. “Contract” as used in this Exhibit shall mean the agreement or contract to which this Exhibit is attached.
2. General Terms. Contractor shall secure and maintain at its own expense each type of insurance, with the applicable minimum coverage limits, as specified in this Exhibit. Contractor shall secure the required insurance policies prior to performing any work, activity, or service under this Contract. Contractor shall maintain such policies throughout the term of this Contract, unless a longer period is required pursuant to the provisions herein. Any insurance carried by Contractor is primary insurance and shall not be considered contributory with any insurance carried by GoTriangle. In the event that any portion of Contractor’s obligations under this Contract are subcontracted by Contractor, then Contractor shall require each subcontractor to secure and maintain insurance satisfying the requirements of this Exhibit, or in the alternative, Contractor may secure and maintain the insurance on the subcontractor’s behalf. The insurance requirements set forth in this Exhibit do not modify or otherwise relieve Contractor of Contractor’s other obligations as stated elsewhere in this Contract.
3. Commercial General Liability. Contractor shall secure and maintain occurrence-form Commercial General Liability insurance, including coverage for premises and operations, products and completed operations, independent contractors, personal injury and blanket contractual liability, with limits of not less than: General Aggregate (\$2 million); Products and Completed Operations Aggregate (\$2 million); Personal and Advertising Injury Aggregate (\$1 million); and Each Occurrence (\$1 million). Such insurance shall be primary and non-contributory with any insurance carried by GoTriangle.
4. Worker’s Compensation and Employer’s Liability. Contractor shall secure and maintain Worker’s Compensation insurance complying with North Carolina statutory requirements covering all employees and owners, and including Employer’s Liability coverage with limits of not less than \$1 million per accident, \$1 million disease per policy limit, and \$1 million disease per employee limit. Coverage shall extend to all states in which operations are conducted.
5. Automobile Liability. Contractor shall secure and maintain Automobile Liability insurance with a limit of not less than \$1 million combined single limit. Such insurance shall include coverage for all owned, hired, and non-owned motorized vehicles both on and off the project site. Such insurance shall be primary and non-contributory with any insurance carried by GoTriangle.
6. Umbrella/Excess Liability. Contractor shall secure and maintain Umbrella or Excess Liability insurance on a “following form” basis with a limit of not less than \$1 million providing excess coverage over and above Contractor’s primary insurance for Commercial General Liability, Automobile Liability, and Employer’s Liability. Such insurance shall be primary and non-contributory with any insurance carried by GoTriangle.
7. Professional Liability. Contractor shall secure and maintain Professional Liability insurance providing coverage for errors or omissions committed in the course of Contractor’s performance under this Contract. The coverage shall be maintained during the term of this Contract and for at least 3 years

following completion of Contractor's performance. The policy shall have limits of not less than \$5 million per claim and in the annual aggregate. The policy may contain a deductible of a maximum of \$250,000, but in such case the deductible shall be the sole responsibility of Contractor, and no portion of the deductible is the responsibility of GoTriangle.

8. Privacy and Network Liability (Cyber). Contractor shall secure and maintain Privacy and Network Liability (Cyber) insurance with a limit of not less than \$5 million aggregate and providing coverage for network security, third party liability, notification services, and cyber extortion.
9. Other Terms.
 - 9.1. Qualified Insurers. Contractor shall secure and maintain the required insurance policies from insurance carriers authorized to conduct business in the State of North Carolina with a current A.M. Best rating of "A-" or better.
 - 9.2. Waiver of Subrogation. The following policies of insurance shall include a waiver of subrogation in favor of Research Triangle Regional Public Transportation Authority dba GoTriangle: Commercial General Liability; Worker's Compensation and Employer's Liability; Automobile Liability; and Umbrella/Excess.
 - 9.3. Additional Insured. The following policies of insurance shall name Research Triangle Regional Public Transportation Authority dba GoTriangle as an additional insured: Commercial General Liability; Automobile Liability; and Umbrella/Excess Liability.
 - 9.4. Notice to GoTriangle. If any required coverage lapses for any reason, Contractor shall provide immediate written notice to GoTriangle. Each policy shall also contain notification provisions whereby GoTriangle will receive not less than 30 days' written notice prior to the cancellation of the policy.
 - 9.5. Claims-made Insurance. If any insurance policy required by this Exhibit is secured on a claims-made basis, then such policy shall provide that:
 - 9.5.1. The retroactive date shall coincide with or precede Contractor's commencement of performance under this Contract (including subsequent policies purchased as renewals or replacements);
 - 9.5.2. The policy shall allow for the reporting of circumstances or incidents that might give rise to future claims;
 - 9.5.3. Contractor shall maintain similar insurance under the same terms and conditions for at least 3 years following completion of all performance under this Contract; and
 - 9.5.4. If insurance is terminated for any reason, Contractor shall purchase an extended reporting provision of at least 3 years to report claims arising from Contractor's performance.

- 9.6. Deductibles and Self-insured Retention. GoTriangle will review all deductible and self-insured retention (SIR) amounts and may require Contractor to secure alternate insurance when in GoTriangle's sole discretion such amounts are not reasonable under the circumstances. The payment of any deductible is the sole responsibility of Contractor.
- 9.7. Certificates of Insurance. Before commencing performance under this Contract, for each required policy Contractor shall furnish a certificate of insurance (COI) to GoTriangle that demonstrates coverage in compliance with the requirements of this Exhibit and includes the following:
- 9.7.1. Effective and expiration dates of the policy
 - 9.7.2. Amount of any deductible or self-insured retention
 - 9.7.3. Any exclusions to the policy which are not part of the standard form
 - 9.7.4. Reference to GoTriangle Contract Number identified on the first page of this Exhibit
 - 9.7.5. Title block formatted as follows: **Research Triangle Regional Public Transportation Authority dba GoTriangle, PO Box 13787, Research Triangle Park, NC 27709**

Attachment D- E-Verify Form

GOTRIANGLE E-VERIFY EMPLOYER COMPLIANCE STATEMENT

E-Verify for Public Contracts: HB 786 (S.L. 2013-418)

The legislation referenced prohibits governmental units from awarding to or entering into contracts unless the contractor and the contractor's subcontractors comply with the E-Verify requirements of Article 2 of Chapter 64 of the NC General Statutes.

Contractor, hereafter Employer, understands that E-Verify is a federal program operated by the United States Department of Homeland Security and other federal agencies, or any successor or equivalent program used to verify the work authorization of newly hired employees pursuant to federal law. Employer is defined as: Any person, business entity, or other organization that transacts business in

this State and that employs 25 or more employees in this State. This term does not include State agencies, counties, municipalities, or other governmental bodies.

Employer understands that Employers, as Defined Herein, Must Use E-Verify. Each employer, after hiring an employee to work in the United States, shall verify the work authorization of the employee through E-Verify in accordance with NCGS§64-26(a).

Therefore, all employers must be in compliance with the E-Verify requirements to enter into contracts with Triangle Transit.

Below check the type of employer and complete the information.

A) **Employer with less than 25 employees**, not required to use E-Verify: _____

Company Name: _____

Name and title of Authorized Signer(s): _____

Date: _____

OR:

B) **Employer with 25 or more employees** required by NC S.L.213-418 to use E-Verify:
Yes, we comply:

Company Name: _____

Name and title of Authorized Signer(s): _____

Date: _____

ATTACHMENT E

Contractor's Statement of Sales/Use Tax Paid
Sales and Use Taxes Paid on Materials Purchased for the Construction of the

Invoice Date	Invoice Number	Company Name	Type of Material Purchased	Cost of Material	Amount of Sales/Use Taxes Paid	County Where Sales/Use Taxes Paid
Total				\$0.00	\$0.00	

Construction Group A-1 – Contractor's Statement of Sales/Use Tax Paid TTA Solicitation 24-047

Attachment- F

IFB Number (if applicable): _____

Name of Vendor or Bidder: _____

**IRAN DIVESTMENT ACT CERTIFICATION
REQUIRED BY N.C.G.S. 143C-6A-5(a)**

As of the date listed below, the vendor or bidder listed above is not listed on the Final Divestment List created by the State Treasurer pursuant to N.C.G.S. 143-6A-4.

The undersigned hereby certifies that he or she is authorized by the vendor or bidder listed above to make the foregoing statement.

Signature

Date

Printed Name

Title

Notes to persons signing this form:

N.C.G.S. 143C-6A-5(a) requires this certification for bids or contracts with the State of North Carolina, a North Carolina local government, or any other political subdivision of the State of North Carolina. The certification is required at the following times:

- When a bid is submitted
- When a contract is entered into (if the certification was not already made when the vendor made its bid)
- When a contract is renewed or assigned

N.C.G.S. 143C-6A-5(b) requires that contractors with the State, a North Carolina local government, or any other political subdivision of the State of North Carolina must not utilize any subcontractor found on the State Treasurer's Final Divestment List.

The State Treasurer's Final Divestment List can be found on the State Treasurer's website at the address www.nctreasurer.com/iran and will be updated every 180 days.

Attachment - G

Companies Boycotting Israel Divestment Act Certification Form

RFP/RFQ Number (if applicable): _____

Name of Contracting Party or Bidder: _____

COMPANIES BOYCOTTING ISRAEL DIVESTMENT ACT CERTIFICATION REQUIRED BY N.C.G.S. §147-86.81et seq. *

Pursuant to N.C.G.S. §147-86.81, any person identified as engaging in a boycott of Israel, as defined by this Act. In addition, State agencies must divest from investments in such restricted companies, determined by appearing on the Final Divestment List created by the State Treasurer pursuant to G.S. 147-86.81, is ineligible to contract with the State of North Carolina or any political subdivision of the State.

As of the date listed below, the supplier or bidder listed above is not listed on the Final Divestment List created by the State Treasurer pursuant to N.C.G.S. §147-86.81.

The undersigned hereby certifies that he or she is authorized by the contracting party or bidder listed above to make the foregoing statement.

Signature

Date

Printed Name

Title

N.C.G.S. §147-86.81 requires this certification for bids or contracts with the State of North Carolina, a North Carolina local government, or any other political subdivision of the State of North Carolina. The certification is required at the following times:

- When a bid is submitted
- When a contract is entered into (if the certification was not already made when the vendor made its bid)
- When a contract is renewed or assigned

N.C.G.S. § 147-86.81(b) requires that contractors with the State, a North Carolina local government, or any other political subdivision of the State of North Carolina must not utilize any subcontractor found on the State Treasurer's Final Divestment List.

The State Treasurer's Final Divestment List can be found on the State Treasurer's website at: <https://www.nctreasurer.com/inside-the-department/OpenGovernment/Pages/Divestment-Acts-Resources.aspx> and will be updated every 180 days.

* Note: Enacted by Session Law 2017-193 as N.C.G.S. §147-86.81et seq.

Attachment H



CERTIFICATION REGARDING CONFLICT OF INTEREST

The Submitter is required to certify that performance of the work will not create any conflicts of interest or disclose any actual or potential conflicts of interest by completing and signing one of the following statements:

The Submitter hereby certifies that to the best of its knowledge and belief, and in accordance with GoTriangle’s “Procedures and Guidelines for Preventing Organizational Conflicts of Interest and RFP Section 2 performance of the services described in the Scope of Work will not create any conflicts of interest for the Submitter, any affiliates, any proposed subconsultants, and key personnel of any of these organizations.

DATE: _____

AUTHORIZED SIGNATURE: _____

TITLE: _____

SUBMITTER/COMPANY NAME: _____

OR

The Submitter hereby discloses the following circumstances that could give rise to a conflict of interest for the Submitter, any affiliates, any proposed subconsultants, and key personnel of any of these organizations. (Attach additional sheets as needed.)

Name of the Individual/Company to which potential conflict of interest might apply:

Nature of potential conflict of interest:

Attachment H

Proposed Remedy:

DATE: _____

AUTHORIZED SIGNATURE: _____

TITLE: _____

SUBMITTER/COMPANY NAME: _____

Attachment I

PROPOSER STATEMENT OF NON-COLLUSION

BY SUBMISSION OF THIS PROPOSAL, PROPOSER AND EACH PERSON SIGNING ON BEHALF OF PROPOSER CERTIFIES AS TO ITS OWN ORGANIZATION, UNDER PENALTY OF PERJURY, THAT TO THE BEST OF HIS/HER KNOWLEDGE AND BELIEF:

- (1) The prices of this proposal have been arrived at independently, without collusion, consultation, communication, or agreement with any other Proposer or competitor, for the purposes of restricting competition or as to any matter relating to price.
- (2) Unless otherwise required by law, the prices quoted in this proposal have not been knowingly disclosed by Proposer and will not be disclosed by Proposer directly or indirectly to any other Proposer or competitor before proposals are opened.
- (3) No attempt has been made or will be made by the Proposer to induce any other person, partnership or corporation to submit or not to submit a bid on any portion of the Project work.

IF, FOR ANY REASON, PROPOSER CANNOT CERTIFY AS SET FORTH ABOVE, PROPOSER SHALL SO STATE AND SET FORTH THE REASONS IN DETAIL BELOW:

Subscribed to under penalty of perjury under the laws of the State of North Carolina, this _____ day of _____, 20____ as the act and deed of said corporation or partnership.

Name (print):

Title:

Company:

"General Decision Number: NC20240011 09/06/2024

Superseded General Decision Number: NC20230011

State: North Carolina

Construction Type: Building

County: Wake County in North Carolina.

BUILDING CONSTRUCTION PROJECTS (does not include single family homes or apartments up to and including 4 stories).

Note: Contracts subject to the Davis-Bacon Act are generally required to pay at least the applicable minimum wage rate required under Executive Order 14026 or Executive Order 13658. Please note that these Executive Orders apply to covered contracts entered into by the federal government that are subject to the Davis-Bacon Act itself, but do not apply to contracts subject only to the Davis-Bacon Related Acts, including those set forth at 29 CFR 5.1(a)(1).

If the contract is entered into on or after January 30, 2022, or the contract is renewed or extended (e.g., an option is exercised) on or after January 30, 2022:	Executive Order 14026 generally applies to the contract. The contractor must pay all covered workers at least \$17.20 per hour (or the applicable wage rate listed on this wage determination, if it is higher) for all hours spent performing on the contract in 2024.
---	---

If the contract was awarded on or between January 1, 2015 and January 29, 2022, and the contract is not renewed or extended on or after January 30, 2022:	Executive Order 13658 generally applies to the contract. The contractor must pay all covered workers at least \$12.90 per hour (or the applicable wage rate listed on this wage determination, if it is higher) for all hours performing on that contract in 2024.
---	--

The applicable Executive Order minimum wage rate will be adjusted annually. If this contract is covered by one of the Executive Orders and a classification considered necessary for performance of work on the contract does not appear on this

wage determination, the contractor must still submit a conformance request.

Additional information on contractor requirements and worker protections under the Executive Orders is available at <http://www.dol.gov/whd/govcontracts>.

Modification Number	Publication Date
0	01/05/2024
1	09/06/2024

* ELEC0553-001 12/01/2023

	Rates	Fringes
ELECTRICIAN.....	\$ 30.00	14.5% +8.30

IRON0848-003 07/01/2023

	Rates	Fringes
IRONWORKER.....	\$ 28.00	17.10

PLUM0421-006 07/01/2023

	Rates	Fringes
PIPEFITTER.....	\$ 33.96	13.48

* SUNC2018-011 08/08/2023

	Rates	Fringes
BRICKLAYER.....	\$ 20.42	0.00
CARPENTER.....	\$ 20.48	3.12
CEMENT MASON/CONCRETE FINISHER...	\$ 17.94	0.00
LABORER: Common or General.....	\$ 14.67 **	2.07
LABORER: Mason Tender - Brick...	\$ 13.52 **	0.00
LABORER: Mason Tender - Cement/Concrete.....	\$ 15.26 **	0.00
LABORER: Pipelayer.....	\$ 15.00 **	0.00
OPERATOR: Backhoe/Excavator/Trackhoe.....	\$ 25.00	0.00
OPERATOR: Bulldozer.....	\$ 17.77	3.01

OPERATOR: Forklift.....	\$ 16.00 **	0.00
OPERATOR: Grader/Blade.....	\$ 22.68	3.27
OPERATOR: Roller.....	\$ 15.31 **	1.46
PAINTER.....	\$ 15.55 **	1.05
PLUMBER.....	\$ 23.66	6.60
ROOFER.....	\$ 18.26	4.38
SHEET METAL WORKER.....	\$ 19.67	13.27
TRUCK DRIVER: Dump Truck.....	\$ 16.56 **	3.09

WELDERS - Receive rate prescribed for craft performing operation to which welding is incidental.

=====

** Workers in this classification may be entitled to a higher minimum wage under Executive Order 14026 (\$17.20) or 13658 (\$12.90). Please see the Note at the top of the wage determination for more information. Please also note that the minimum wage requirements of Executive Order 14026 are not currently being enforced as to any contract or subcontract to which the states of Texas, Louisiana, or Mississippi, including their agencies, are a party.

Note: Executive Order (EO) 13706, Establishing Paid Sick Leave for Federal Contractors applies to all contracts subject to the Davis-Bacon Act for which the contract is awarded (and any solicitation was issued) on or after January 1, 2017. If this contract is covered by the EO, the contractor must provide employees with 1 hour of paid sick leave for every 30 hours they work, up to 56 hours of paid sick leave each year. Employees must be permitted to use paid sick leave for their own illness, injury or other health-related needs, including preventive care; to assist a family member (or person who is like family to the employee) who is ill, injured, or has other health-related needs, including preventive care; or for reasons resulting from, or to assist a family member (or person who is like family to the employee) who is a victim of, domestic violence, sexual assault, or stalking. Additional information on contractor requirements and worker protections under the EO is available at <https://www.dol.gov/agencies/whd/government-contracts>.

Unlisted classifications needed for work not included within the scope of the classifications listed may be added after award only as provided in the labor standards contract clauses (29CFR 5.5 (a) (1) (iii)).

The body of each wage determination lists the classification and wage rates that have been found to be prevailing for the cited type(s) of construction in the area covered by the wage determination. The classifications are listed in alphabetical order of ""identifiers"" that indicate whether the particular rate is a union rate (current union negotiated rate for local), a survey rate (weighted average rate) or a union average rate (weighted union average rate).

Union Rate Identifiers

A four letter classification abbreviation identifier enclosed in dotted lines beginning with characters other than ""SU"" or ""UAVG"" denotes that the union classification and rate were prevailing for that classification in the survey. Example: PLUM0198-005 07/01/2014. PLUM is an abbreviation identifier of the union which prevailed in the survey for this classification, which in this example would be Plumbers. 0198 indicates the local union number or district council number where applicable, i.e., Plumbers Local 0198. The next number, 005 in the example, is an internal number used in processing the wage determination. 07/01/2014 is the effective date of the most current negotiated rate, which in this example is July 1, 2014.

Union prevailing wage rates are updated to reflect all rate changes in the collective bargaining agreement (CBA) governing this classification and rate.

Survey Rate Identifiers

Classifications listed under the ""SU"" identifier indicate that no one rate prevailed for this classification in the survey and the published rate is derived by computing a weighted average rate based on all the rates reported in the survey for that classification. As this weighted average rate includes all rates reported in the survey, it may include both union and non-union rates. Example: SULA2012-007 5/13/2014. SU indicates the rates are survey rates based on a weighted average calculation of rates and are not majority rates. LA indicates the State of Louisiana. 2012 is the year of survey on which these classifications and rates are based. The next number, 007 in the example, is an internal number used in producing the wage determination. 5/13/2014 indicates the survey completion date for the classifications and rates under that identifier.

Survey wage rates are not updated and remain in effect until a new survey is conducted.

Union Average Rate Identifiers

Classification(s) listed under the UAVG identifier indicate that no single majority rate prevailed for those classifications; however, 100% of the data reported for the classifications was union data. EXAMPLE: UAVG-OH-0010 08/29/2014. UAVG indicates that the rate is a weighted union average rate. OH indicates the state. The next number, 0010 in the example, is an internal number used in producing the wage determination. 08/29/2014 indicates the survey completion date for the classifications and rates under that identifier.

A UAVG rate will be updated once a year, usually in January of each year, to reflect a weighted average of the current negotiated/CBA rate of the union locals from which the rate is based.

State Adopted Rate Identifiers

Classifications listed under the ""SA"" identifier indicate that the prevailing wage rate set by a state (or local) government was adopted under 29 C.F.R. §1.3(g)-(h). Example: SAME2023-007 01/03/2024. SA reflects that the rates are state adopted. ME refers to the State of Maine. 2023 is the year during which the state completed the survey on which the listed classifications and rates are based. The next number, 007 in the example, is an internal number used in producing the wage determination. 01/03/2024 reflects the date on which the classifications and rates under the ?SA? identifier took effect under state law in the state from which the rates were adopted.

WAGE DETERMINATION APPEALS PROCESS

1.) Has there been an initial decision in the matter? This can be:

- * an existing published wage determination
- * a survey underlying a wage determination
- * a Wage and Hour Division letter setting forth a position on a wage determination matter
- * a conformance (additional classification and rate) ruling

On survey related matters, initial contact, including requests for summaries of surveys, should be with the Wage and Hour National Office because National Office has responsibility for the Davis-Bacon survey program. If the response from this initial contact is not satisfactory, then the process described in 2.) and 3.) should be followed.

With regard to any other matter not yet ripe for the formal process described here, initial contact should be with the Branch of Construction Wage Determinations. Write to:

Branch of Construction Wage Determinations
Wage and Hour Division
U.S. Department of Labor
200 Constitution Avenue, N.W.
Washington, DC 20210

2.) If the answer to the question in 1.) is yes, then an interested party (those affected by the action) can request review and reconsideration from the Wage and Hour Administrator (See 29 CFR Part 1.8 and 29 CFR Part 7). Write to:

Wage and Hour Administrator
U.S. Department of Labor
200 Constitution Avenue, N.W.
Washington, DC 20210

The request should be accompanied by a full statement of the interested party's position and by any information (wage payment data, project description, area practice material, etc.) that the requestor considers relevant to the issue.

3.) If the decision of the Administrator is not favorable, an interested party may appeal directly to the Administrative Review Board (formerly the Wage Appeals Board). Write to:

Administrative Review Board
U.S. Department of Labor
200 Constitution Avenue, N.W.
Washington, DC 20210

4.) All decisions by the Administrative Review Board are final.

END OF GENERAL DECISION"

ATTACHMENT- K

GUIDE TO M/WBE REQUIRED FORMS

All GoTriangle's procurements have a section entitled "**MINORITY AND WOMEN OWNED BUSINESS ENTERPRISE REQUIREMENTS.**" This section of procurement sets forth the established GoTriangle's goal for this particular procurement and also describes the forms that must be completed with their proposal. Below is a summary of the forms used in the GoTriangle M/WBE Participation Program by a Consultant.

Form #1: Consultant M/WBE Utilization Plan - This document must be completed by all Consultants responding to RFPs with an M/WBE goal greater than zero. The Consultant must demonstrate how it plans to meet the stated M/WBE goal. In completing this form, the Consultant should describe the steps taken to establish communication with M/WBE firms and identify current or future relationships with certified M/WBE firms. The second page of the form should list the M/WBE certified firms that the vendor plans to engage with on the project and the amount that each certified firm is projected to be paid. Plans to work with uncertified firms do not meet the criteria for participation. If the plan is not submitted or is deemed deficient, the Consultant may be sent a notice of deficiency. It is mandatory that all awards with goals have a utilization plan on file.

Form #2: M/WBE Utilization Waiver Request - This document must be filled out by the Consultant if the utilization plan (Form #1) indicates less than the stated participation goal for the procurement. In this instance, Form #2 must accompany Form #1 with the proposal. When completing Form #2, it is important that the Consultant thoroughly document the steps that were taken to meet the goal and provide evidence in the form of attachments to the document. The required attachments are listed on Form #2 and will document the good-faith efforts taken to meet the desired goal. A Consultant can also attach additional evidence outside of those referenced attachments. Without evidence of good-faith efforts, in the form of attachments or other documentation, GoTriangle may not approve the waiver and the Consultant may be deemed non-responsive.

New M/WBE firms are being certified daily and new M/WBE firms may now be available to provide products or services that were historically unavailable. If Form #2 is found by GoTriangle to be deficient, the Consultant will be sent a deficiency letter and may be deemed non-responsive.

Any questions regarding completion of these forms can be sent to procurement@gotriangle.org

**M/WBE Form #1
CONSULTANT M/WBE UTILIZATION PLAN**

Consultant Name:	
Vendor ID:	Telephone No.
RFP/Contract Title:	RFP/Contract No.

Description of Plan to Meet M/WBE Goals (Use pages 3-4 to provide specific MBE and WBE subcontractor information)

PROJECTED M/WBE USAGE IN PERCENTAGE

	%
1. MBE Goal Applied to Eligible Costs	
2. WBE Goal Applied to Eligible Costs	
3. M/WBE Combined Totals*	

*If less than the stated goal in RFP, Form #2 is required.

**CONSULTANT PROPOSED MBE UTILIZATION PLAN
MINORITY OWNED BUSINESS ENTERPRISE (MBE) INFORMATION**

**In order to achieve the MBE 17.1 % Goal, Consultant expects to subcontract with North Carolina Department of Transportation certified MINORITY-OWNED entities as follows:
(add additional pages as needed)**

MBE Firm (Exactly as Registered)	Description of Work (Products/Services) [MBE]	Projected MBE Percentage
Name Address City, State, ZIP Employer I.D. Telephone Number () -		_____
Name Address City, State, ZIP Employer I.D. Telephone Number () -		_____
Name Address City, State, ZIP Employer I.D. Telephone Number () -		_____

**CONSULTANT PROPOSED WBE UTILIZATION PLAN
WOMEN OWNED BUSINESS ENTERPRISE (WBE) INFORMATION**

**In order to achieve the WBE Goal of %, Consultant expects to subcontract with North Carolina Department of Transportation certified WOMEN-OWNED entities as follows:
(add additional pages as needed)**

WBE Firm (Exactly as Registered)	Description of Work (Products/Services) [WBE]	Projected WBE Percentage
Name Address City, State, ZIP Employer I.D. Telephone Number () -		\$ _____
Name Address City, State, ZIP Employer I.D. Telephone Number () -		\$ _____
Name Address City, State, ZIP Employer I.D. Telephone Number () -		\$ _____

M/WBE Form #2

M/WBE UTILIZATION WAIVER REQUEST

Consultant Name :	DATE:		
Address:	RFP No.:		
City, State, Zip Code:	M/WBE Goals: MBE____% WBE ____% (From Lines 1&2 of Form 1)		
By submitting this form and the required information, the officer or/consultant certifies that every Good Faith Effort has been taken to promote M/WBE participation pursuant to the M/WBE requirements set forth under this solicitation.			
Consultant is requesting a :			
<input type="checkbox"/> MBE Waiver – A waiver of the MBE Goal for this procurement is requested. Total <input type="checkbox"/> / Partial <input type="checkbox"/> check one <input type="checkbox"/> WBE Waiver – A waiver of the WBE Goal for this procurement is requested. Total <input type="checkbox"/> / Partial <input type="checkbox"/> check one <input type="checkbox"/> Waiver Pending Certification – (Check here if subcontractors or suppliers of Consultant are not certified M/WBE, but an application for certification has been filed.) Date of such filing:			
<u>If a total or partial waiver is requested, appropriate supporting documentation of Good Faith Efforts shall be provided as instructed on page 6.</u>			
<hr/> <table style="width: 100%; border: none;"> <tr> <td style="width: 50%;">PREPARED BY (Signature)</td> <td style="width: 50%;">Date:</td> </tr> </table> <p>By signing and submitting this form, the contractor certifies that a good faith effort has been made to promote M/WBE participation pursuant to the M/WBE requirements set forth under this solicitation. Failure to submit complete and accurate information may result in a finding of noncompliance and deemed non-responsive.</p>		PREPARED BY (Signature)	Date:
PREPARED BY (Signature)	Date:		
Name and Title of Preparer (Printed or Typed):	Telephone Number:		
Email Address:			
Submit with the bid or proposal	*****FOR GOTRIANGLE USE ONLY *****		
	<table style="width: 100%; border: none;"> <tr> <td style="width: 80%;">REVIEWED BY:</td> <td style="width: 20%;">DATE:</td> </tr> </table>	REVIEWED BY:	DATE:
	REVIEWED BY:	DATE:	
Waiver Granted: <input type="checkbox"/> YES <input type="checkbox"/> NO MBE: <input type="checkbox"/> WBE: <input type="checkbox"/> <input type="checkbox"/> Total Waiver <input type="checkbox"/> Partial Waiver <input type="checkbox"/> Certification Waiver <input type="checkbox"/> Notice of Deficiency Issued _____			

Explanation why Consultant is unable to meet M/WBE goals for this project:

Include attachments below to evidence good faith efforts:

- Attachment A. List of the general circulation, trade and M/WBE-oriented publications and dates of publications soliciting for certified M/WBE participation as a subcontractor/supplier and copies of such solicitation.
- Attachment B. List of the certified M/WBEs appearing in the NCDOT M/WBE directory that were solicited for this contract. Provide proof of dates or copies of the solicitations and copies of the responses made by the certified M/WBEs. Describe specific reasons that responding certified M/WBEs were not selected.
- Attachment C. Descriptions of the contract documents/plans/specifications made available to certified M/WBEs by the contractor when soliciting their participation and steps taken to structure the scope of work for the purpose of subcontracting with or obtaining supplies from certified M/WBEs.
- Attachment D. Description of the negotiations between the contractor and certified M/WBEs for the purposes of complying with the M/WBE goals of this contract.
- Attachment E. Identify dates of any pre-proposal, pre-award or other meetings attended by consultant.
- Attachment F. Other information deemed relevant to the request.

**THIS DOCUMENT MUST BE SUBMITTED WITH EACH PAY REQUEST AND
FINAL PAYMENT
MBE/WBE DOCUMENTATION FOR CONTRACT
PAYMENTS**

Prime Consultant: _____
 Address & Phone Number: _____
 Project Name: _____
 Pay Application Number: _____ Period: _____

The following is a list of payments to be made to minority business sub-consultants on this project for the above-mentioned period.

Minority Firm Name and Address	Minority Category MBE/WBE*	Amount Paid For This Period	Amount Paid To Date
_____	_____	_____	_____
_____	_____	_____	_____
_____	_____	_____	_____
_____	_____	_____	_____
_____	_____	_____	_____
_____	_____	_____	_____
_____	_____	_____	_____
_____	_____	_____	_____
_____	_____	_____	_____
_____	_____	_____	_____

*Minority Categories: Black, African American (B), Hispanic (H), Asian American (AA), American Indian (AI), Female (WF), Socially and Economically Disadvantaged (SE), and Disabled (D).

Total MBE % for this Period: _____ Total WBE % for this Period: _____

ATTACHMENT- L

RFP RESPONSE CHECKLIST

Table of Contents

1.0 Vendor Response Checklist	2
2.0 Vendor Attachments.....	2

1.0 Proposer Response Checklist

ALL FORMS AND REQUIRED INFORMATION BELOW MUST BE COMPLETED AND INCLUDED WHEN YOU SUBMIT YOUR PROPOSAL PACKAGE:

Table 1 Vendor Response Checklist

Item #	Proposal Response Item	Completed and Provided as Instructed	
		YES <input type="checkbox"/>	NO <input type="checkbox"/>
1	A. Cover Sheet	YES <input type="checkbox"/>	NO <input type="checkbox"/>
2	B. Table of Contents	YES <input type="checkbox"/>	NO <input type="checkbox"/>
3	C. Concise Letter of Interest	YES <input type="checkbox"/>	NO <input type="checkbox"/>
4	D. Statement of Judgments	YES <input type="checkbox"/>	NO <input type="checkbox"/>
5	E. Understanding of Scope of Work	YES <input type="checkbox"/>	NO <input type="checkbox"/>
6	F. Qualifications and Experience	YES <input type="checkbox"/>	NO <input type="checkbox"/>
7	G. Previous Experience of Similar Scope of Work	YES <input type="checkbox"/>	NO <input type="checkbox"/>
8	H. References from Previous Clients	YES <input type="checkbox"/>	NO <input type="checkbox"/>
9	I. Start-Up and Transition Plan	YES <input type="checkbox"/>	NO <input type="checkbox"/>
10	J. Attachments	YES <input type="checkbox"/>	NO <input type="checkbox"/>

2.0 Proposer Attachments

The Proposer must complete the following table identifying all the other documents that are being attached as part of the RFP response.

Table 2 Vendor Attachment Checklist

Item #	Attachment Name	Attachment Provided?	
		YES <input type="checkbox"/>	NO <input type="checkbox"/>
1	A. Proposal Submittal Form (Attachment A)	YES <input type="checkbox"/>	NO <input type="checkbox"/>
2	B. Bid Form (Attachment B)	YES <input type="checkbox"/>	NO <input type="checkbox"/>
3	C. Minimum Insurance Requirements (Attachment C)	YES <input type="checkbox"/>	NO <input type="checkbox"/>
4	D. E-Verify Form (Attachment D)	YES <input type="checkbox"/>	NO <input type="checkbox"/>
5	E. Contractor's Statement of Sales/Use Tax (Attachment E)	YES <input type="checkbox"/>	NO <input type="checkbox"/>
6	F. Iran Divestment Act Form (Attachment F)	YES <input type="checkbox"/>	NO <input type="checkbox"/>
7	G. Companies Boycotting Israel Divestment Act Form (Attachment G)	YES <input type="checkbox"/>	NO <input type="checkbox"/>
8	H. Certificate Regarding Conflict of Interest (Attachment H)	YES <input type="checkbox"/>	NO <input type="checkbox"/>
9	I. Non - Collusion (Attachment I)	YES <input type="checkbox"/>	NO <input type="checkbox"/>
10	J. Davis – Bacon Rate Forms (Attachment J)	YES <input type="checkbox"/>	NO <input type="checkbox"/>
11	K. W/BE Forms (Attachment K)	YES <input type="checkbox"/>	NO <input type="checkbox"/>
12	L. RFP Response Checklist (Attachment L)	YES <input type="checkbox"/>	NO <input type="checkbox"/>

Exhibit A-1



Bus Stop Improvements - #A-1 Durham, NC

City of Durham Approved		DATE
ENGINEERING		DATE
STORMWATER		DATE
TRANSPORTATION		DATE
WATER MANAGEMENT		DATE
FLOODPLAIN		DATE

Sheet List Table

1	Cover Sheet
2	General Notes
3	Details
4	Details
5	Details
6	Details
7	6128 - Stadium Dr at Wyldewood Rd (Foxfire Apts)
8	6604 - Stadium Dr at Wyldewood Rd (NB)
9	5600 - Carver St at Commons Blvd (WB)
10	6366 - Carver St at Commons Blvd (EB)
11	5495 - Clarendon St at Club Blvd NW
12	5404 - E Main St at Hyde Park Ave (WB)
13	6086 - E Main St at Hyde Park Ave (EB)
14	5689 - S Roxboro St at Umstead St
15	5054 - University Dr at Larchmont Rd
16	6276 - S Alston Ave at Duke Health (SB)
17	5424 - S Roxboro St at Bond St
18	6061 - Ross Rd at Fernando St

VICINITY MAP

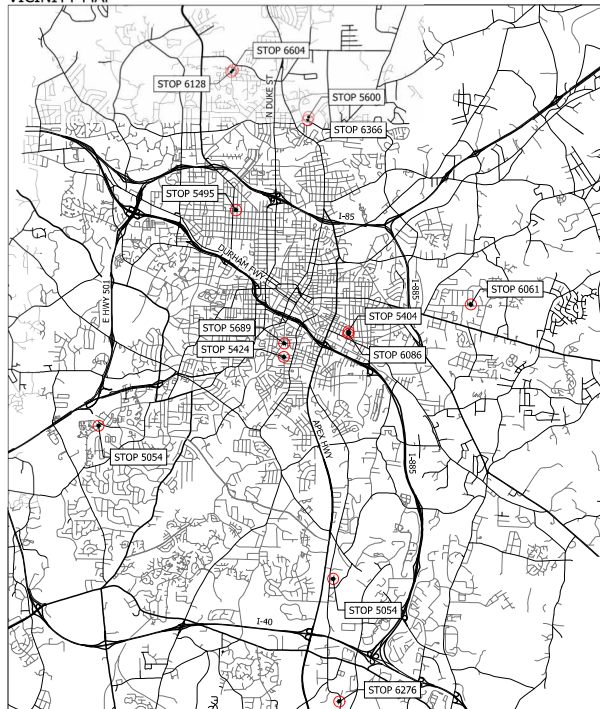

- PUBLIC WORKS SPECIAL CONDITIONS OF APPROVAL
- THE DESIGNING PROFESSIONAL (A NOTE, NOTES OR NOLA—AS REQUIRED) SHALL SUBMIT THREE (3) SETS OF CONSTRUCTION DRAWINGS TO THE PUBLIC WORKS DEPARTMENT—DEVELOPMENT REVIEW FOR REVIEW AND APPROVAL. CONSTRUCTION DRAWING APPROVAL IS REQUIRED PRIOR TO COMMENCING CONSTRUCTION (SEE CONSTRUCTION PLAN APPROVAL PROCESS). THE APPROVAL OF CONSTRUCTION DRAWINGS IS SEPARATE FROM SITE PLAN APPROVAL. CITY OFFICIALS SHALL REVIEW ALL SIZES, MATERIALS, SLABES, LOCATIONS, EXTENSIONS AND DEPTHS FOR ALL MANHOLES UTILITIES MATERIALS, SANITARY SEWER LINES AND STORM DRAINAGE CONDUIT SYSTEMS) FOR COMPLIANCE WITH ALL APPLICABLE REGULATORY STANDARDS, SPECIFICATIONS, AND BEST MANAGEMENT PRACTICES.
 - THE DESIGNING PROFESSIONAL (A NOTE, NOTES OR NOLA—AS REQUIRED) SHALL SUBMIT ONE (1) SET OF AS-BUILT DRAWINGS TO THE PUBLIC WORKS DEPARTMENT—DEVELOPMENT REVIEW FOR REVIEW AND APPROVAL. AS-BUILT DRAWING APPROVAL IS REQUIRED PRIOR TO WATER METER INSTALLATION AND/OR SANITARY SEWER SERVICE CONNECTION AND PRIOR TO ISSUANCE OF A CERTIFICATE OF OCCUPANCY.
 - FIRE FLOW ANALYSIS REQUIRED FOR REVIEW AND APPROVAL AS PART OF THE CONSTRUCTION DRAWING APPROVAL PROCESS. TO SUBMIT FLOW TEST OR TO OBTAIN CURRENT SYSTEM DATA, COMPLETE THE ONLINE APPLICATION (HTTP://WWW.DURHAMNC.GOV/ASSETS/FILES/591838.DOC).
 - IF A WATER METER OR LARGER IS PROPOSED, CONTACT WATER MANAGEMENT AT 566-4381 PRIOR TO THE CONSTRUCTION OF THE METER WALL TO VERIFY THE TYPE AND DIMENSIONS OF THE METERS.
 - WATER PERMIT REQUIRED AFTER CONSTRUCTION DRAWING APPROVAL AND PRIOR TO COMMENCING WATER MAIN INSTALLATION.
 - SEWER PERMIT REQUIRED AFTER CONSTRUCTION DRAWING APPROVAL AND PRIOR TO COMMENCING SANITARY SEWER MAIN INSTALLATION.
 - SEWER PERMIT FROM DURHAM COUNTY REQUIRED, CONTACT DURHAM COUNTY UTILITY DIVISION AT 566-9933.
 - PIPES AND/OR STRUCTURES SHOWN IN THE EROSION CONTROL PLAN OF THE SITE PLAN THAT ARE PROPOSED TO BE PERMANENT WILL BE REVIEWED AND APPROVED AS PART OF THE GRADING PLAN DURING CONSTRUCTION DRAWING REVIEW. THEIR PIPES AND/OR STRUCTURES MAY NOT BE INSTALLED PRIOR TO CONSTRUCTION DRAWING APPROVAL AND NUMBER OF INSPECTION HES.
 - WHEN PROJECT HAS JOBS ON MORE LOTS: "A SECOND WATERLINE FEE IS REQUIRED PRIOR TO THE 100% CERTIFICATE OF COMPLIANCE."
 - WHEN DRAWING AN EXISTING POND: "ALL ROAD AND FILL SECTIONS THAT ARE TO BE CONSTRUCTED OVER EXISTING POND FEATURES OR WETLANDS WILL REQUIRE ALL UNSUITABLE SOILS TO BE EXCAVATED AND STRUCTURAL ROAD FILL TO BE INSTALLED. SPECIAL CONSTRUCTION STANDARDS WILL ALSO BE REQUIRED. A LICENSED GEOTECHNICAL ENGINEER WILL BE REQUIRED TO PROVIDE THE NECESSARY ANALYSIS. THE CITY OF DURHAM WILL REVIEW AND APPROVE THE ANALYSIS DURING CONSTRUCTION DRAWING REVIEW."
 - AN INCOSET OR CITY OF DURHAM DRIVEWAY PERMIT IS REQUIRED.
 - CITY OF DURHAM REFERENCE GUIDE FOR DEVELOPMENT 2010-04-05 PAGE 24.
 - AND THE FOLLOWING NOTES UNDER PUBLIC WORKS AND CLEAR MARKS ARE PROPOSED:
PROVIDE STAKEMARKS ARE TO BE USED, SEE CITY OF DURHAM CURB CUTS DETAILS
HTTP://WWW.DURHAMNC.GOV/DOCUMENTCENTER/INDEXVIEW.CLS
FOR MARKS BY TIGHT EXISTING UNDEVELOPED AREAS WITH SMALL HOUSES (DOWNTOWN, ETC.) IT IS RECOMMENDED SPECIFIC MARK DETAILS ARE NEEDED TO PREVENT CONSTRUCTION DELAYS, THE NUMBER TO MAKE IT WORK IS ON THE DESIGNING ENGINEER.
 - IF CONSTRUCTION DRAWINGS ARE NOT REQUIRED AFTER SITE PLAN APPROVAL, PROVIDE THE FOLLOWING NOTES INSTEAD OF NOTE 1 ABOVE:
PROVIDE TWO (2) SETS OF APPROVED SITE PLAN DOCUMENTS TO ENGINEERING INSPECTORS, 3RD FLOOR, 153 CITY HALL PLAZA, DURHAM, NC 27703 AT LEAST 5 DAYS PRIOR TO BEGINNING CONSTRUCTION AND CONTACT ENGINEERING INSPECTORS AT 919-566-6055 AT LEAST 48 HOURS PRIOR TO BEGINNING CONSTRUCTION.
A CONSTRUCTION OR CITY RIGHT-OF-WAY / PRIVATE PROPERTY PERMIT IS REQUIRED FOR THE PROPOSED URBAN INFRASTRUCTURE INCLUDING PERMITS CONTACT THE PUBLIC WORKS AT THE DEVELOPMENT SERVICES CENTER AT 566-4266.
AN ENGAGEMENT AGREEMENT MAY BE REQUIRED. CONTACT ENGINEERING SERVICES AT 919-566-4526.

CONTACT INFORMATION:

CONTRACTOR TO CONTACT BONG VANG AT GOTRIANGLE
PRIOR TO CONSTRUCTION OF BUS STOPS.

Bong Vang
bvang@gotriangle.org
919.485.7557

FOR DESIGN AND ENGINEERING QUESTIONS:

Josh Hurst, PE
jhurst@kittelson.com
984.275.2713

KITTELSON & ASSOCIATES

1000 S. DURHAM AVENUE
SUITE 410
DURHAM, NC 27701

PROJECT NO. **26947**

SHEET NO. **1**

DATE: _____

SCALE: _____

PROJECT: **Bus Stop Improvements - #A-1**

CITY: **Durham, NC**

COVER SHEET

File: H:\2016\26947 - GOTriangle - Planning and Design\DCP\01 - Durham Bus Stop Design\Kittelson_CADD - General Sheets\construction - 1.dwg
 Plot Date: 08/25/24 1:50:20 PM - Joshua Smith
 Plot Path: H:\2016\26947 - GOTriangle - Planning and Design\DCP\01 - Durham Bus Stop Design\Kittelson_CADD - General Sheets\construction - 1.dwg

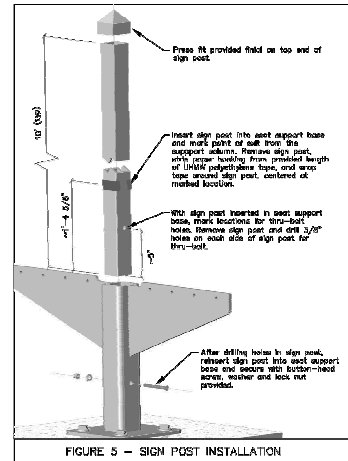
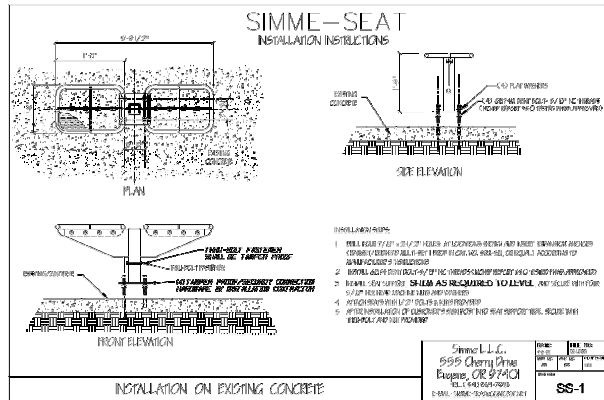
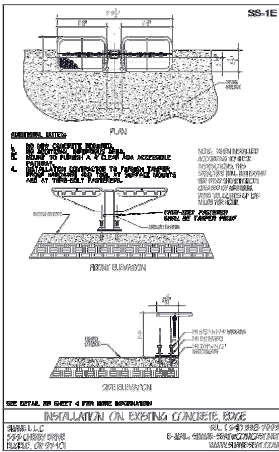

ENGINEERING	DATE
STOPWATCHER	_____
TRANSPIRE (OTHER)	_____
WATER MANAGEMENT	_____
FLOODPLAIN	_____

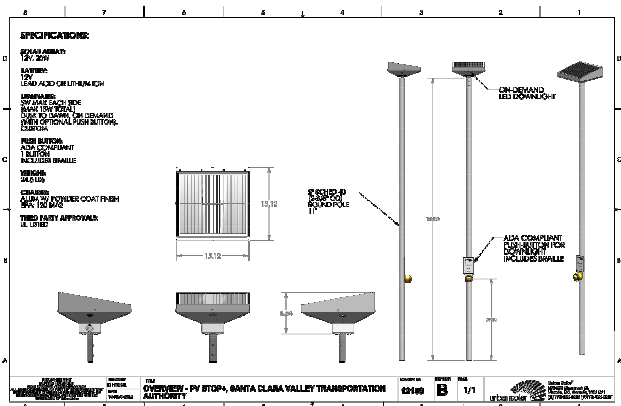
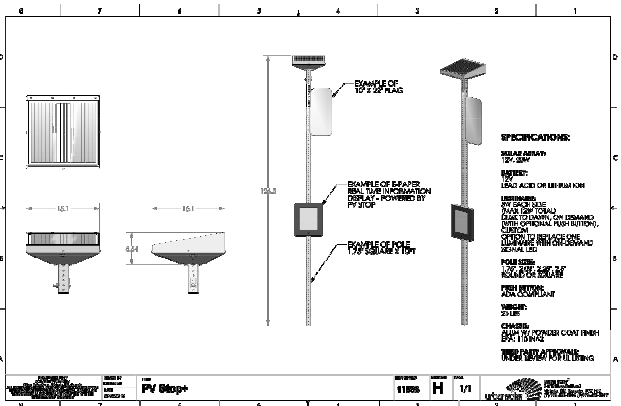

Triangle
Durham

KITTELSON & ASSOCIATES

100 DURHAM ROAD, SUITE 410
 DURHAM, NC 27704-1231

PROJECT NO: 26947

SHEET NO: 3

PROJECT NO.	26947
SUBMISSION DATE	08/25/14
DESIGNED BY	DES
CHECKED BY	KCH

Bus Stop Improvements - #A-1
Durham, NC

DETAILS

DATE

PROVISION

SHEET NO. 4

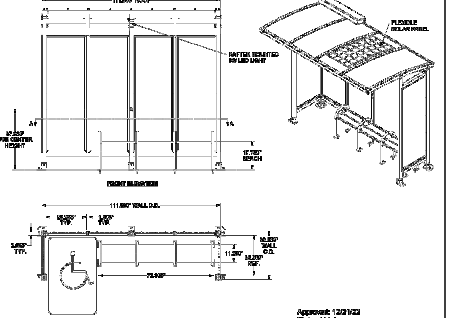
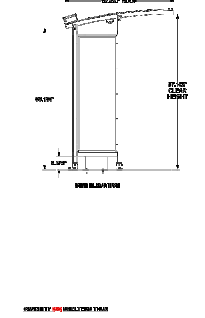
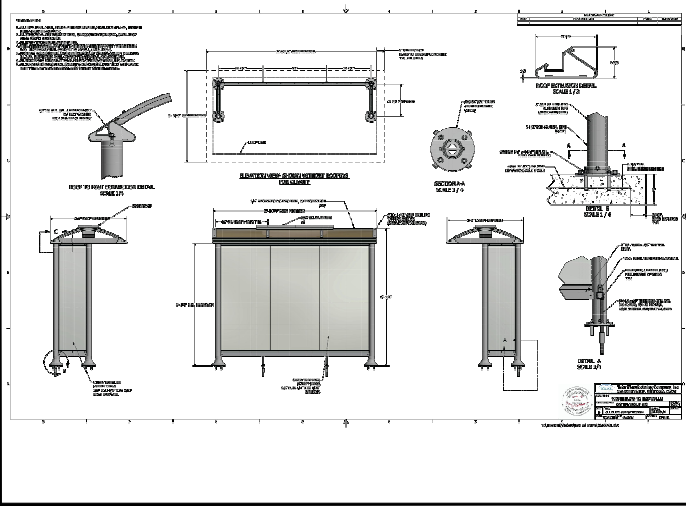
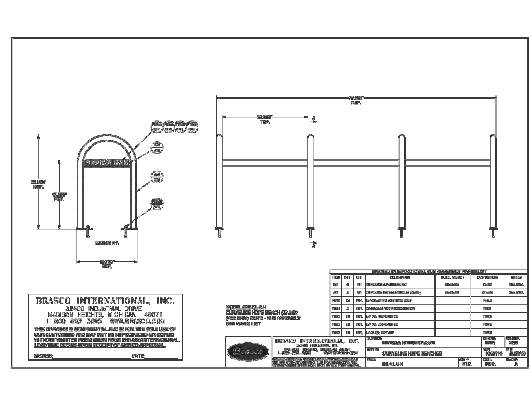
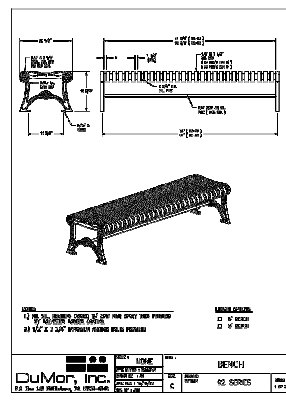
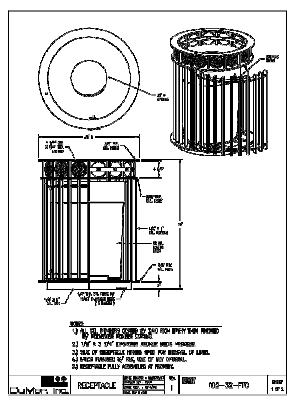
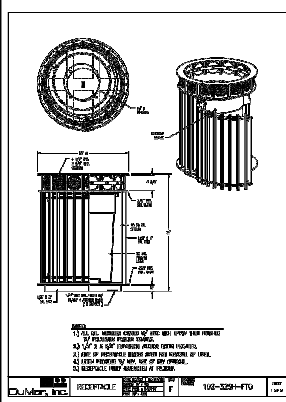

GENERAL NOTES:

- 1. REFER TO ALL NOTES ON SHEET #A-1 FOR DIMENSIONS AND MATERIALS.
- 2. ALL DIMENSIONS ARE UNLESS OTHERWISE SPECIFIED.
- 3. ALL DIMENSIONS ARE TO FACE UNLESS OTHERWISE SPECIFIED.
- 4. ALL DIMENSIONS ARE TO CENTER UNLESS OTHERWISE SPECIFIED.
- 5. ALL DIMENSIONS ARE TO CENTER UNLESS OTHERWISE SPECIFIED.
- 6. ALL DIMENSIONS ARE TO CENTER UNLESS OTHERWISE SPECIFIED.
- 7. ALL DIMENSIONS ARE TO CENTER UNLESS OTHERWISE SPECIFIED.
- 8. ALL DIMENSIONS ARE TO CENTER UNLESS OTHERWISE SPECIFIED.
- 9. ALL DIMENSIONS ARE TO CENTER UNLESS OTHERWISE SPECIFIED.
- 10. ALL DIMENSIONS ARE TO CENTER UNLESS OTHERWISE SPECIFIED.

APPROVED: 12/21/14
Richard Suter
Director of Capital Development
GetItRight

BRAND INTERNATIONAL, INC.
10000 RUCKELSHAEFER RD., SUITE 410
DURHAM, NC 27703-5231
TEL: 919.286.7000
WWW.BRAND-INTERNATIONAL.COM

US TYPICAL

DATE	BY
DATE	BY
DATE	BY
DATE	BY

City of Durham
APPROVED: _____
DATE: _____

City of Durham
APPROVED: _____
DATE: _____

City of Durham
APPROVED: _____
DATE: _____

City of Durham
APPROVED: _____
DATE: _____



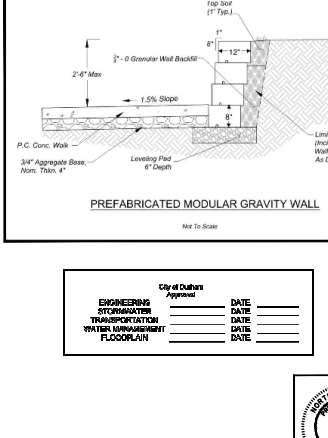
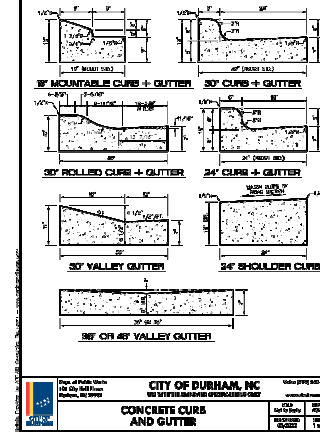
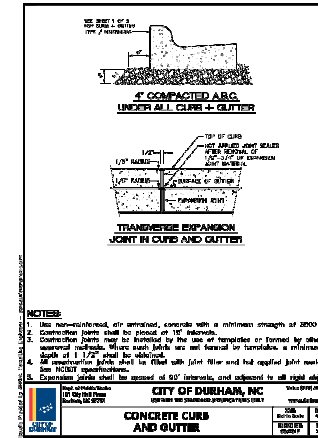
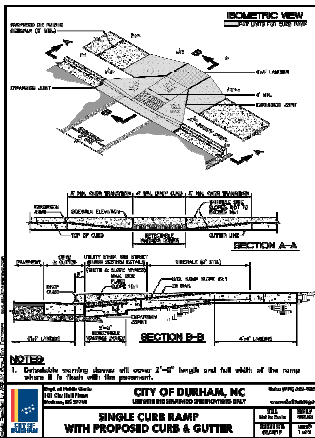
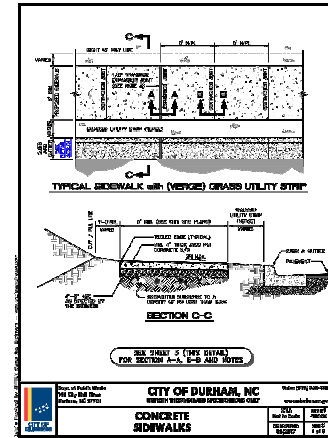
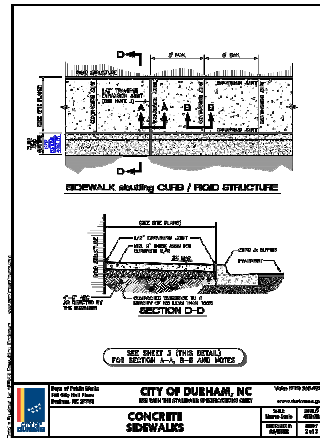
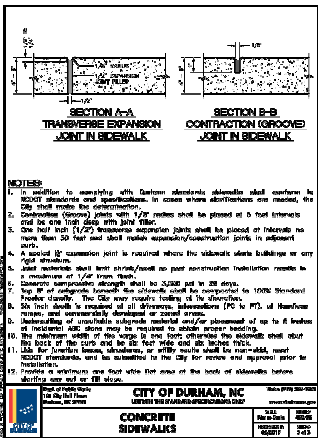
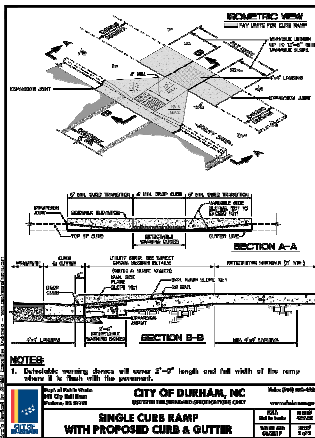

Triangle
Durham

KITTELSON & ASSOCIATES
100 DURHAM ROAD, SUITE 410
DURHAM, NC 27704
919.286.1231

PROJECT NO. 26947
SHEET NO. 5

DATE: _____
DATE: _____
DATE: _____
DATE: _____

City of Durham
Approved: _____
ENGINEERING: _____
STORMWATER: _____
TRANSPORTATION: _____
WATER SUPPLY/SEWER: _____
FLOODPLAIN: _____

SEAL 035074
Professional Engineer
State of North Carolina
No. 30116 (S.E.) 00194000

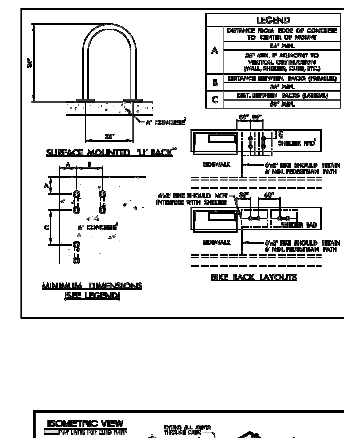
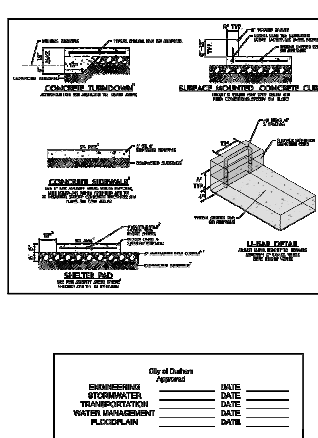
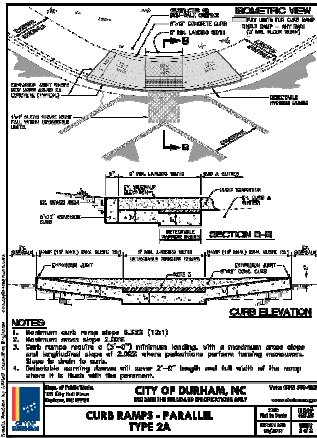
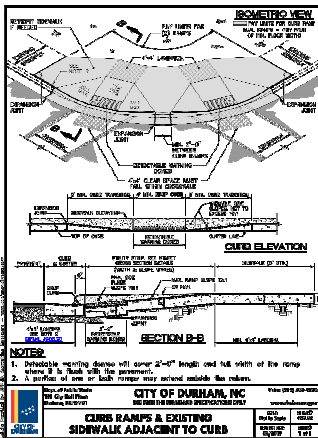

City of Durham	
APPROVED	DATE
DESIGNED BY	DATE
CHECKED BY	DATE
PROJECT NO.	DATE
DRAWING NO.	DATE

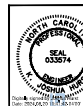
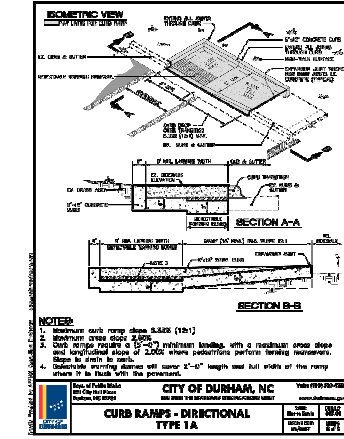
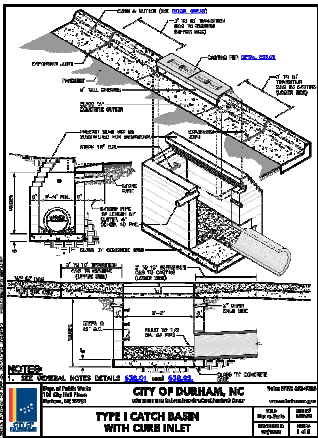
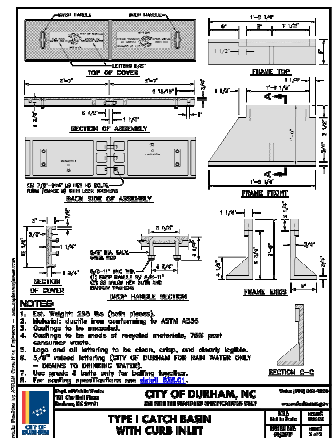
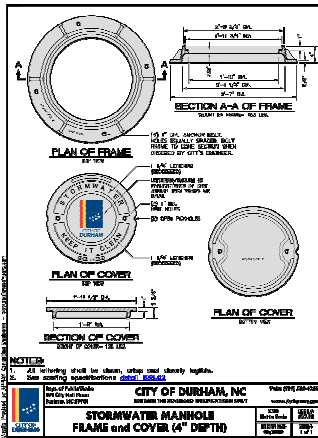

Triangle Durham

KITELSON & ASSOCIATES
 700 DURHAM RD., SUITE 400
 DURHAM, NC 27701
 (919) 286-1231

Submission Date: 08/25/24
 Project No.: 26947
 Drawing No.: K31
 Details

Bus Stop Improvements
 Durham, NC

SHEET NO. 6

EXISTING SURVEY/DEMOLITION PLAN

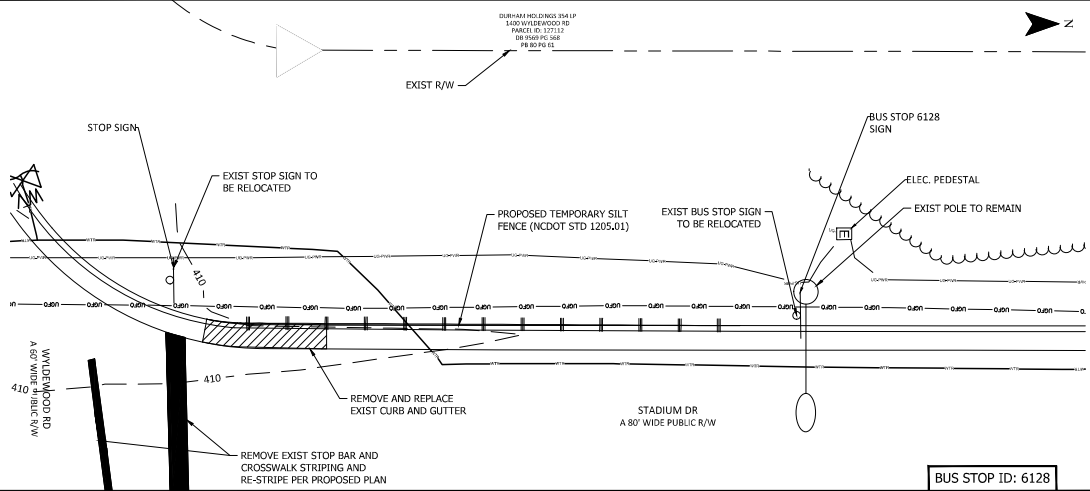
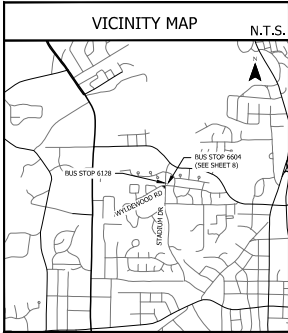

PROPOSED PLAN

- NOTES:**
- SEE GENERAL NOTES, LIST OF STANDARDS, AND DETAILS ON SHEET 02.
 - MOUNT SIGN 7'-0" ABOVE SIDEWALK, 2'-0" MIN AND 8" MAX CLEAR FROM FACE OF CURB TO EDGE OF SIGN.
 - CONTRACTOR TO RETAIN AND PROTECT EXISTING UTILITIES. ANY DAMAGE TO EXISTING UTILITIES WILL REQUIRE THE CONTRACTOR TO REPLACE THE UTILITIES AT NO ADDITIONAL COST TO THE OWNER.
 - REF SHEET 20 FOR PAIRED STOP DESIGN (6604).

MG = MATCH EXISTING GRADE
 PROPOSED BUS SHELTER/LANDING AREA/AMENITY PAD 6' PAD
 PROPOSED 4" CONCRETE

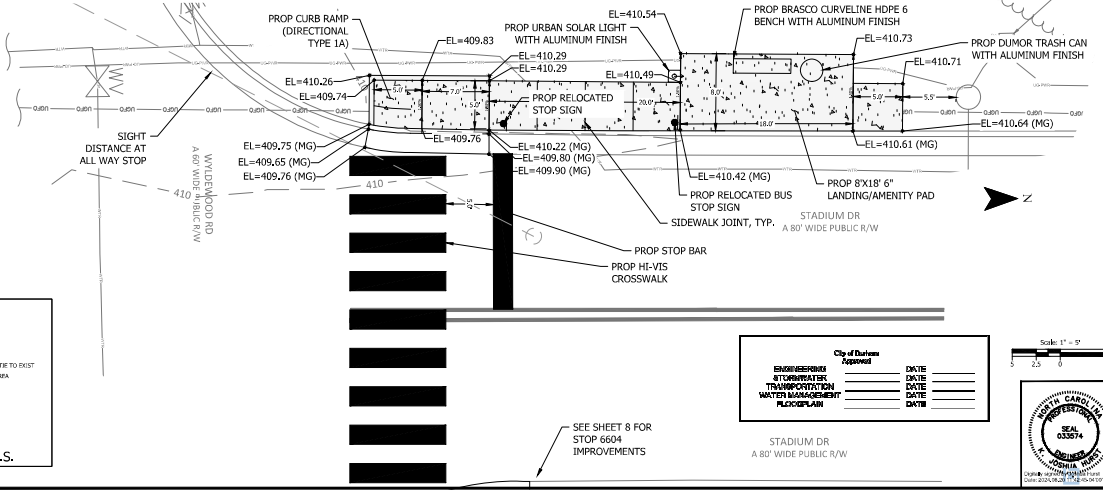
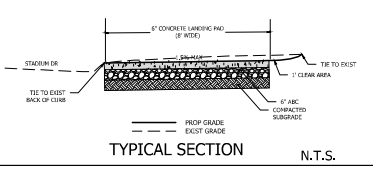

City of Durham Approved

ENGINEER	DATE
INSPECTOR	DATE
TRANSPORTATION	DATE
WATER MANAGEMENT	DATE
FLOODPLAIN	DATE

Scale: 1" = 5'

KITTELSON & ASSOCIATES
 Triangle
 Durham
 NC LICENSE # 043106
 702 CORKLEIN RD, SUITE 410
 #919.251.7371
 #919.251.7372

PROJECT NO.	26947
SHEET NO.	7

6128 - STADIUM DR AT WANDLEWOOD RD (FOOTRE ARTS)

File: H:\Projects\6128\6128.dwg
 Plot Date: 08/15/24 1:51:07 PM
 Plot Scale: 1"=5'
 Plotter: HP DesignJet 4000 Series
 Plot Style: HP-DesignJet4000.ctb
 Plot Path: \\server\plotters\HP DesignJet 4000 Series

EXISTING SURVEY/DEMOLITION PLAN

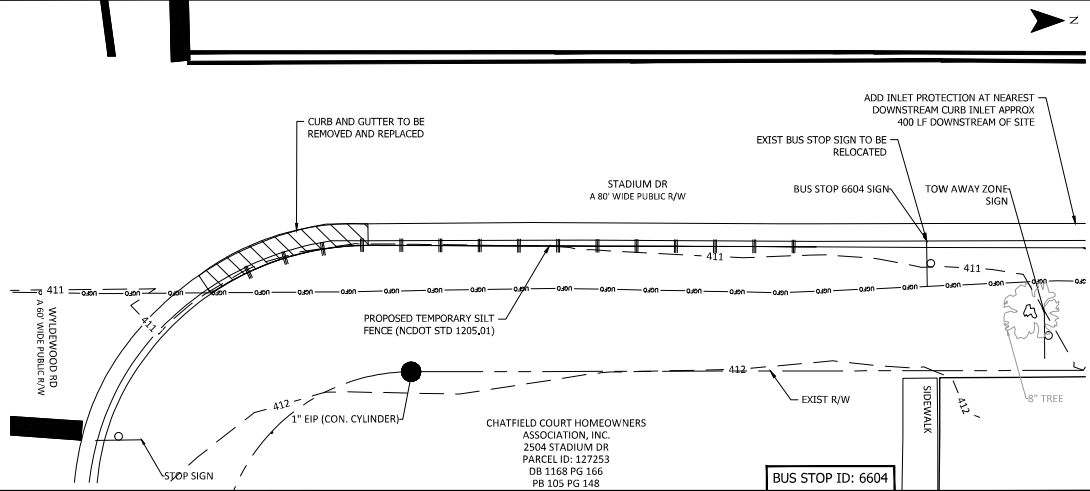
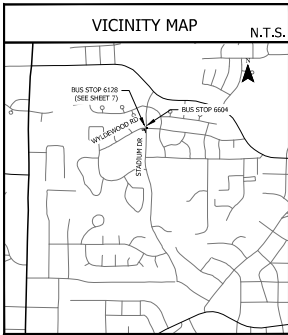

PROPOSED PLAN

- NOTES:**
- SEE GENERAL NOTES, LIST OF STANDARDS, AND DETAILS ON SHEET 02.
 - MOUNT SIGN 7'-0" ABOVE SIDEWALK, 2'-0" MIN AND 8" MAX CLEAR FROM FACE OF CURB TO EDGE OF SIGN.
 - CONTRACTOR TO RETAIN AND PROTECT EXISTING UTILITIES. ANY DAMAGE TO EXISTING UTILITIES WILL REQUIRE THE CONTRACTOR TO REPLACE THE UTILITIES AT NO ADDITIONAL COST TO THE OWNER.
 - REF SHEET 17 FOR PAIRED STOP DESIGN (6128).

MG = MATCH EXISTING GRADE
 PROPOSED BUS SHELTER/LANDING AREA/AMENITY PAD 6' PAD
 PROPOSED 4" CONCRETE

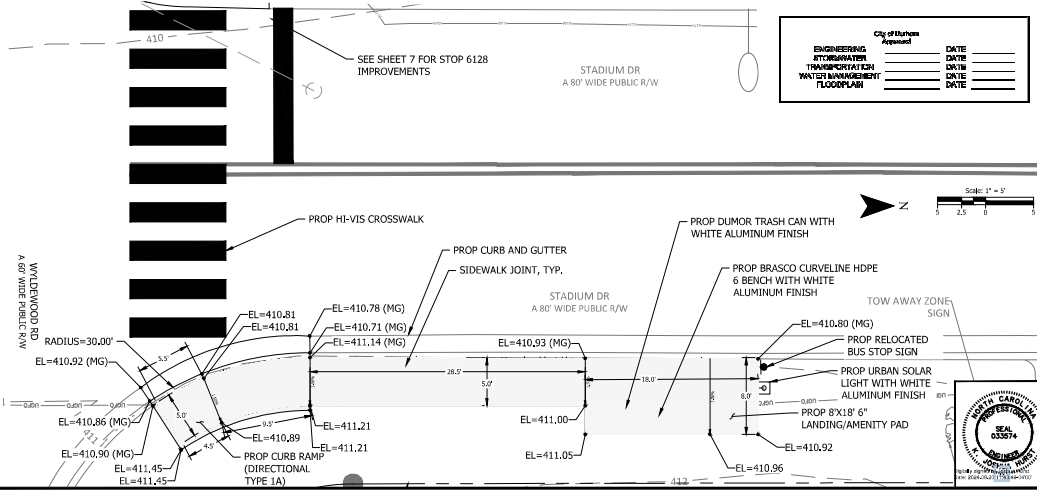
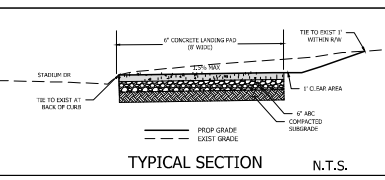

City of Durham Approved	
ENGINEERING	DATE
INSPECTION	DATE
TRANSPORTATION	DATE
WATER MANAGEMENT	DATE
FLOODPLAIN	DATE



Triangle
Durham

KITTELSON & ASSOCIATES
 702 ORIELAN RD, SUITE 400
 DURHAM, NC 27705
 919.286.1231

Submission Date: 08/15/24
 Project No.: 26947
 Project Name: Bus Stop Improvements - #A-1
 Location: 6604 - STADIUM DR AT WILDEWOOD RD (NB)
 Sheet No.: 8

EXISTING SURVEY/DEMOLITION PLAN

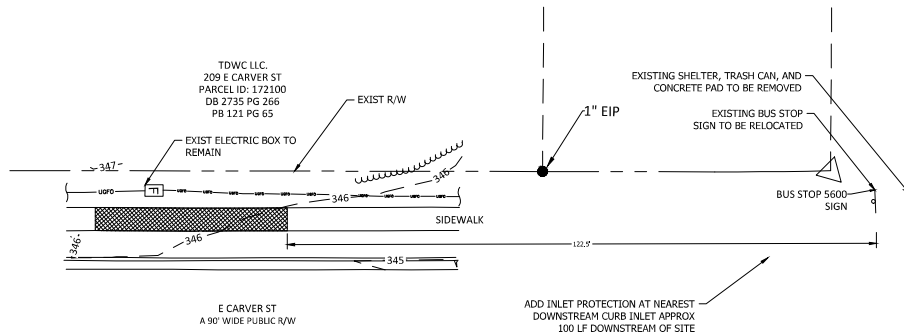
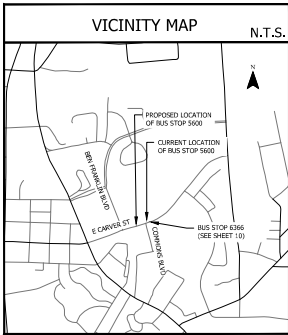

BUS STOP ID: 5600

PROPOSED PLAN

- NOTES:**
- SEE GENERAL NOTES, LIST OF STANDARDS, AND DETAILS ON SHEET 02.
 - MOUNT SIGN 7'-0" ABOVE SIDEWALK, 2'-0" MIN AND 8' MAX CLEAR FROM FACE OF CURB TO EDGE OF SIGN.
 - CONTRACTOR TO RETAIN AND PROTECT EXISTING UTILITIES. ANY DAMAGE TO EXISTING UTILITIES WILL REQUIRE THE CONTRACTOR TO REPLACE THE UTILITIES AT NO ADDITIONAL COST TO THE OWNER.

MG = MATCH EXISTING GRADE
 PROPOSED BUS SHELTER/LANDING AREA/AMENITY PAD 6' PAD
 PROPOSED 4" CONCRETE

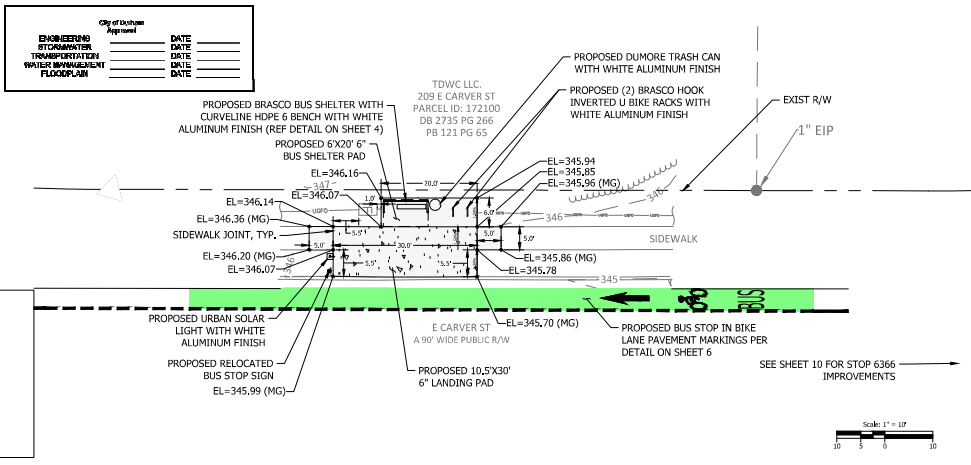
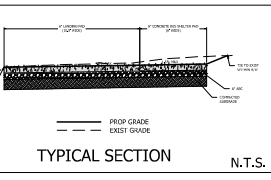

1100 CENTRE POINT RD.
 702 DORSET RD., SUITE 410
 DURHAM, NC 27603
 PH: 919.286.1231
 FAX: 919.286.1232

NO.	REVISION	DATE	BY

Submission Date: 08/15/24
 Project No.: 26947
 Project Name: Bus Stop Improvements - #A-1
 Location: 5600 - CARVER ST. AT COMMONS BLVD (WB)
 Drawing No.: 5600-01
 Drawing Title: Bus Stop Improvements - #A-1
 Drawing Scale: N/A
 Drawing Date: 08/15/24
 Drawing Author: KCH
 Drawing Checker: KCH

Professional Engineer Seal: MICHAEL C. CARTER, License No. 033074, State of North Carolina.

Plot Name: 08/15/24 11:53:46 PM - C:\Users\Smith\OneDrive - KITTTELSON & ASSOCIATES\Projects\26947\Bus Stop Improvements - #A-1\Drawings\5600-01.dwg
 Plot Date: 08/15/24 11:53:46 PM - C:\Users\Smith\OneDrive - KITTTELSON & ASSOCIATES\Projects\26947\Bus Stop Improvements - #A-1\Drawings\5600-01.dwg

EXISTING SURVEY/DEMOLITION PLAN

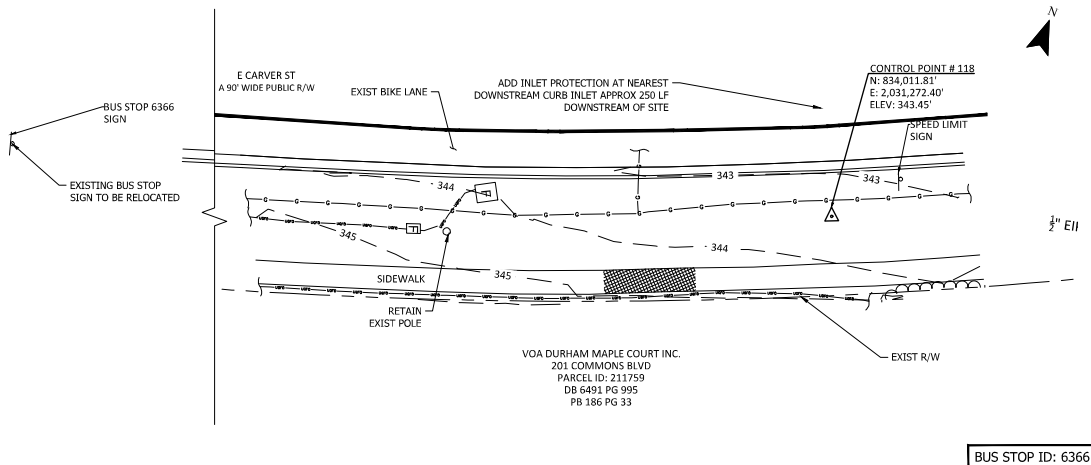
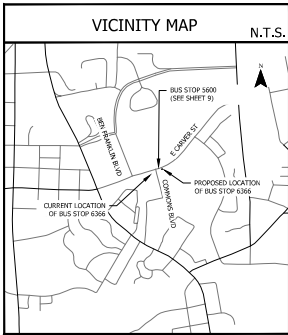

PROPOSED PLAN

- NOTES:**
- SEE GENERAL NOTES, LIST OF STANDARDS, AND DETAILS ON SHEET 02.
 - MOUNT SIGN 7'-0" ABOVE SIDEWALK. 2'-0" MIN AND 8' MAX CLEAR FROM FACE OF CURB TO EDGE OF SIGN.
 - CONTRACTOR TO RETAIN AND PROTECT EXISTING UTILITIES. ANY DAMAGE TO EXISTING UTILITIES WILL REQUIRE THE CONTRACTOR TO REPLACE THE UTILITIES AT NO ADDITIONAL COST TO THE OWNER.

- MG = MATCH EXISTING GRADE
- PROPOSED BUS SHELTER PAD/LANDING AREA/AMENITY 6" PAD
 - PROPOSED 4" CONCRETE

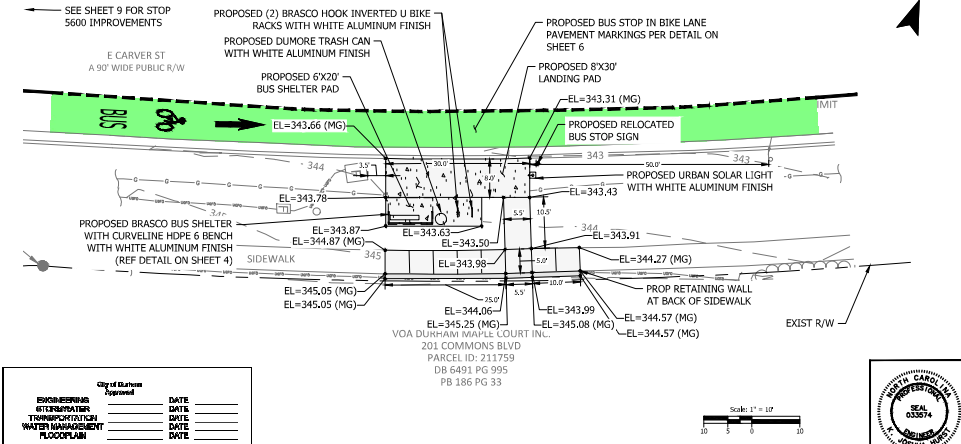
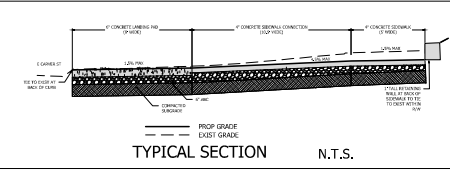

City of Durham		Approved	
ENGINEERING	DATE	DATE	DATE
CONSTRUCTION	DATE	DATE	DATE
TRANSPORTATION	DATE	DATE	DATE
WATER MANAGEMENT	DATE	DATE	DATE
FLOODPLAIN	DATE	DATE	DATE



Triangle Durham

KITTELSON & ASSOCIATES

NC LICENSE # 66-106
702 CORNELIUS RD., SUITE 410
RTP, NC 27608-1205
#910.251.7371

Submission Date: 08/15/24
Project No.: 26947
Project Name: Bus Stop Improvements - #A-1
Project Location: Durham, NC
Project Description: 6366 - CARVER ST AT COMMONS BLVD (EB)

Scale: 1" = 10'

SHEET NO. 10

EXISTING SURVEY/DEMOLITION PLAN

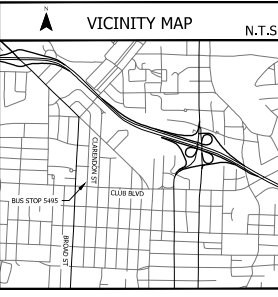

CERTIFICATION OF EXPRESS DEDICATION FOR PUBLIC USE
 City of Durham Reference Guide for Development 2004-01-01 Page 242 (Reconstruction of existing sidewalk and bus stop landing pad) ("Sidewalks") are expressly dedicated to use by the general public. Upon construction of the Sidewalks in conformance with all applicable requirements, City Council may accept the Sidewalks for maintenance by the City of Durham ("City"). Acceptance of the Sidewalks by City Council conveys the right to, enter, enter, and through the Sidewalks, necessary for the City and its agents and contractors, to maintain and repair the sidewalks in the City's sole discretion. The right of ingress/egress to the Sidewalks from the public right of way is also granted to the City so the City can maintain and repair the sidewalks after acceptance. The City in its sole discretion has the right to determine the points of ingress and egress from the public right of way necessary to perform maintenance or repair after acceptance.

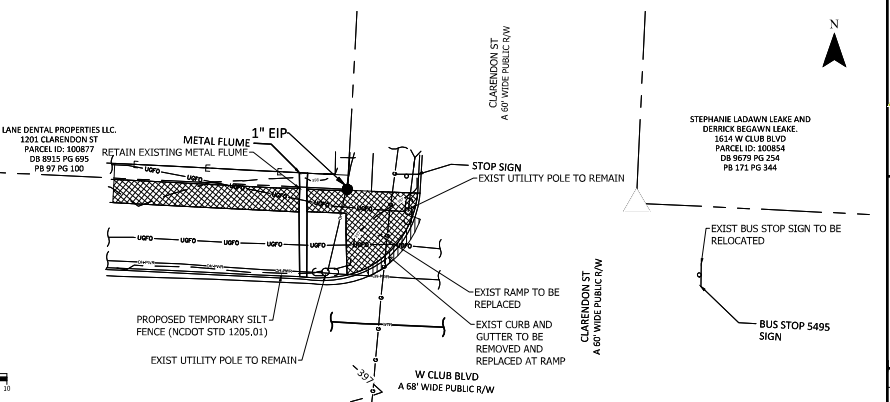

- EXIST ASPHALT AND CURB & GUTTER TO BE REMOVED
- EXIST CONCRETE TO BE REMOVED

BUS STOP ID: 5495

PROPOSED PLAN

- NOTES:**
1. SEE GENERAL NOTES, LIST OF STANDARDS, AND DETAILS ON SHEET 02.
 2. MOUNT SIGN 7'-0" ABOVE SIDEWALK. 2'-0" MIN AND 8" MAX CLEAR FROM FACE OF CURB TO EDGE OF SIGN.
 3. CONTRACTOR TO RETAIN AND PROTECT EXISTING UTILITIES. ANY DAMAGE TO EXISTING UTILITIES WILL REQUIRE THE CONTRACTOR TO REPLACE THE UTILITIES AT NO ADDITIONAL COST TO THE OWNER.
 4. IF ANY DAMAGE OCCURS TO ADJACENT SIDEWALK PANELS, CONTRACTOR TO REPLACE ENTIRE PANEL.

- MG = MATCH EXISTING GRADE
- PROPOSED 4" CONCRETE
- PROPOSED BUS SHELTER/LANDING AREA/AMENITY 6" PAD

TYPICAL SECTION N.T.S.

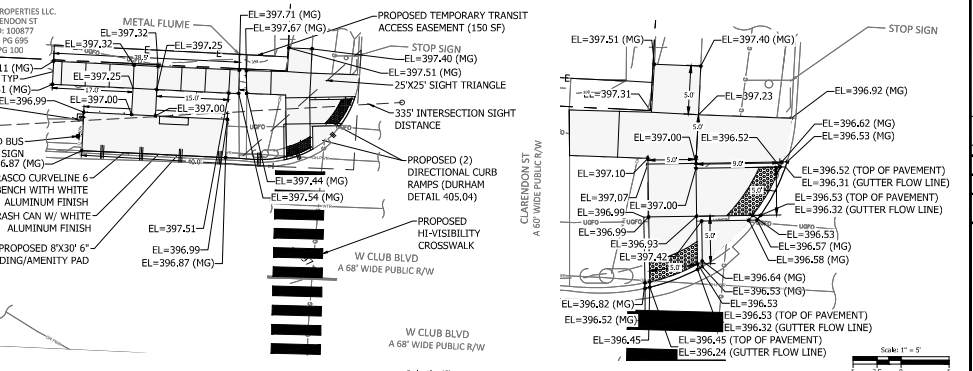
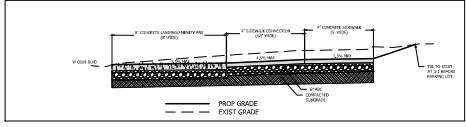

City of Durham		Approved	
INGENIEER	DATE	DATE	DATE
TRANSPORTATION	DATE	DATE	DATE
WARRANTY/IMPROVEMENT	DATE	DATE	DATE
FLOORPLAN	DATE	DATE	DATE

Scale: 1" = 5'

Triangle Durham

KITTELSON & ASSOCIATES
 NC LICENSE #C-106
 702 ORIELLA RD, SUITE 410
 RALEIGH, NC 27605
 P: 919.526.1231
 F: 919.526.1232

Submission Date: 08/15/24
 Project: 26947
 Project No.: 26947
 Project Name: Bus Stop Improvements - #A-1
 Location: Durham, NC
 Description: 5495 - CLARENDON ST AT CLUB BLVD RW

SHEET NO. 11

EXISTING SURVEY/DEMOLITION PLAN

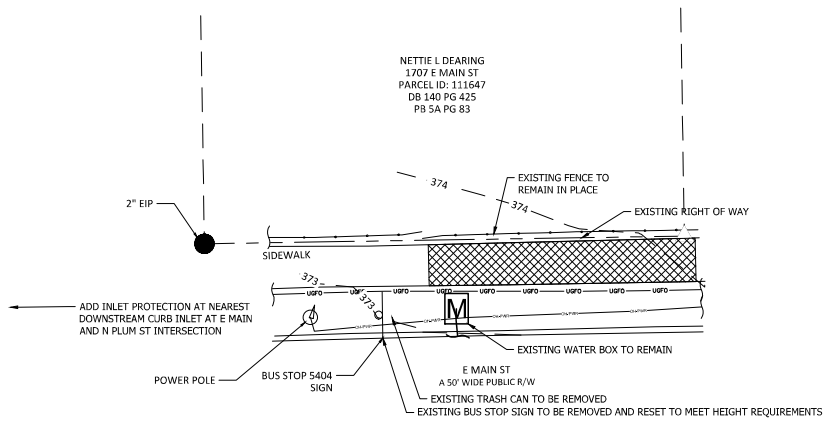
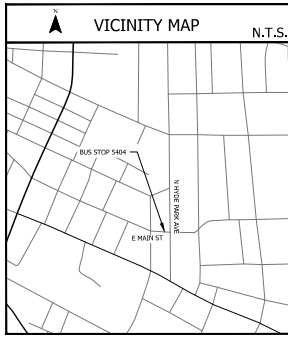

BUS STOP ID: 5404

PROPOSED PLAN

- NOTES:**
- SEE GENERAL NOTES, LIST OF STANDARDS, AND DETAILS ON SHEET 02.
 - MOUNT SIGN 7'-0" ABOVE SIDEWALK, 2'-0" MIN AND 8' MAX CLEAR FROM FACE OF CURB TO EDGE OF SIGN.
 - CONTRACTOR TO RETAIN AND PROTECT EXISTING UTILITIES. ANY DAMAGE TO EXISTING UTILITIES WILL REQUIRE THE CONTRACTOR TO REPLACE THE UTILITIES AT NO ADDITIONAL COST TO THE OWNER.
 - IF ANY DAMAGE OCCURS TO ADJACENT SIDEWALK PANELS, CONTRACTOR TO REPLACE ENTIRE PANEL.
 - CONTRACTOR MUST STAY IN RIGHT OF WAY TO PERFORM ALL WORK. EXISTING FENCE ON PARCEL 111647 TO REMAIN UNDISTURBED.

MG = MATCH EXISTING GRADE
 PROPOSED BUS SHELTER/LANDING AREA/AMENITY PAD 6' PAD
 PROPOSED 4" CONCRETE

City of Durham Approved		DATE
ENGINEERING	_____/_____/____	DATE
TRANSPORTATION	_____/_____/____	DATE
WATER MANAGEMENT	_____/_____/____	DATE
PLANNING	_____/_____/____	DATE

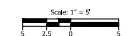
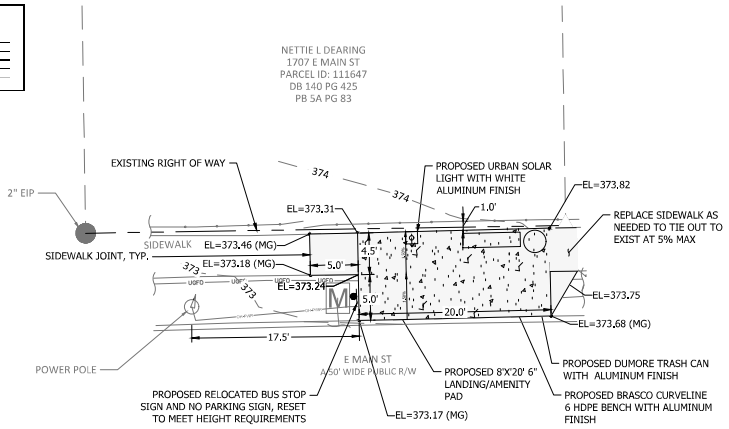
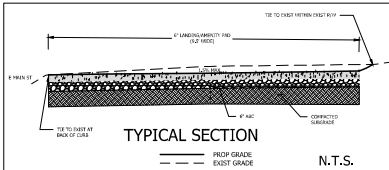

KITTELSON & ASSOCIATES
 150 GORHAM RD., SUITE 410
 DURHAM, NC 27703-7331
 PROJECT NO. 26947
Bus Stop Improvements - #A-1
 Durham, NC
 SHEET NO. 12

File: H:\Projects\26947 - Bus Stop Improvements - Design\DWG\02_Existing.dwg
 Plot Date: 08/15/24 10:50:11 PM
 Plot Path: C:\Users\gsmith\Documents\DWG_Plots\02_Existing.dwg

EXISTING SURVEY/DEMOLITION PLAN

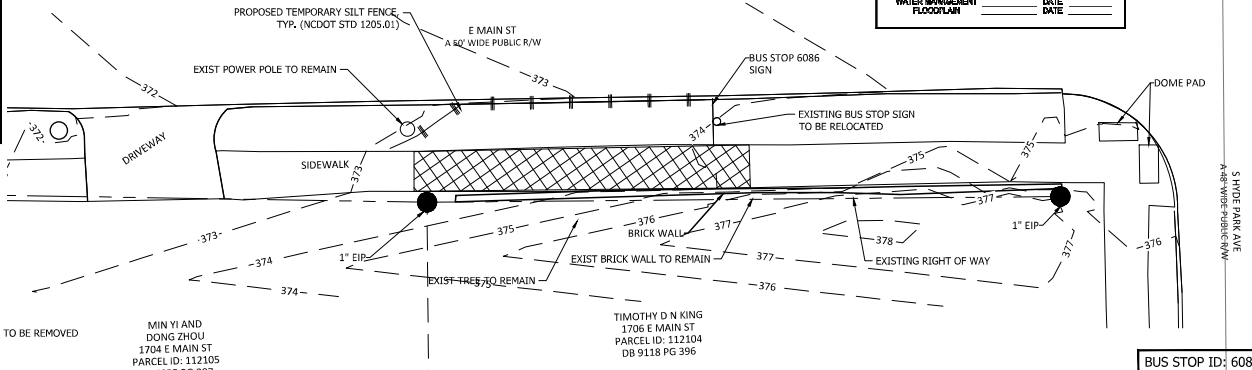
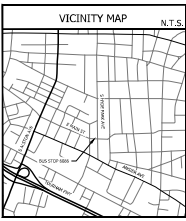

Client: Durham	DATE
SPONSORING	DATE
DESIGNING	DATE
ENGINEERING	DATE
PERMITS/UTILITY	DATE
WATER MANAGEMENT	DATE
FLOODPLAIN	DATE



NC LICENSE # 663706
702 CORNELIUS RD, SUITE 410
DURHAM, NC 27705
ART22

PROPOSED PLAN

- NOTES:
- SEE GENERAL NOTES, LIST OF STANDARDS, AND DETAILS ON SHEET 02.
 - MOUNT SIGN 7'-0" ABOVE SIDEWALK, 2'-0" MIN AND 8" MAX CLEAR FROM FACE OF CURB TO EDGE OF SIGN.
 - CONTRACTOR TO RETAIN AND PROTECT EXISTING UTILITIES. ANY DAMAGE TO EXISTING UTILITIES WILL REQUIRE THE CONTRACTOR TO REPLACE THE UTILITIES AT NO ADDITIONAL COST TO THE OWNER.
 - IF ANY DAMAGE OCCURS TO ADJACENT SIDEWALK PANELS, CONTRACTOR TO REPLACE ENTIRE PANEL.
 - OVERGROWTH AND LEAVES TO BE REMOVED BEFORE CONSTRUCTION OF IMPROVEMENTS.

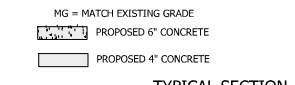

TYPICAL SECTION

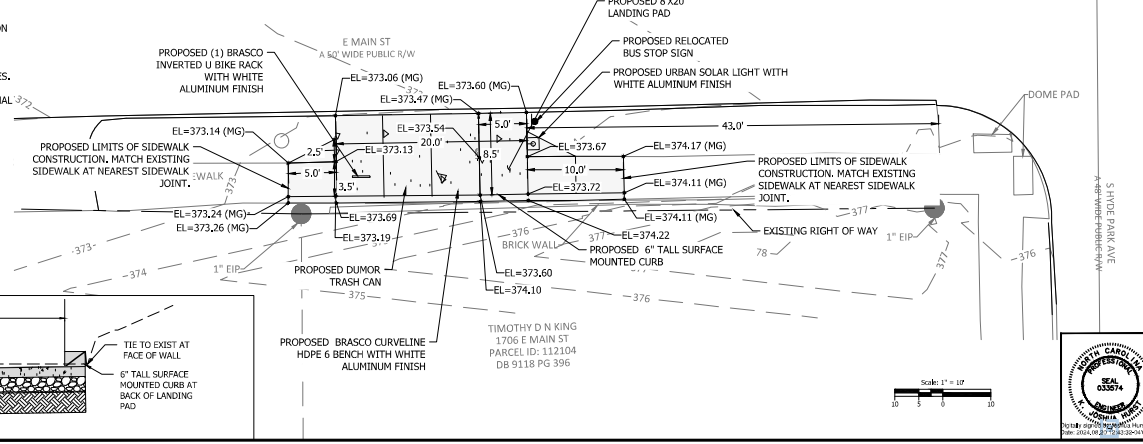
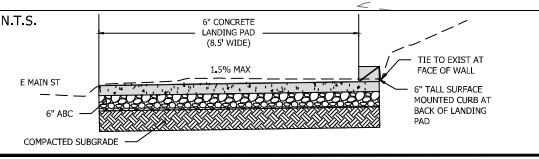

Submission Date	08/25/24
Drawn	CES
Checked	CES
Project No.	26947

Project No. 26947
Bus Stop Improvements - #A-1
Durham, NC
6086 - E MAIN ST AT HYDE PARK AVE (EB)
SHEET NO. 13



File: H:\2024\26947 - Durham Bus Stop Design\DWG\DWG_02.dwg

EXISTING SURVEY/DEMOLITION PLAN

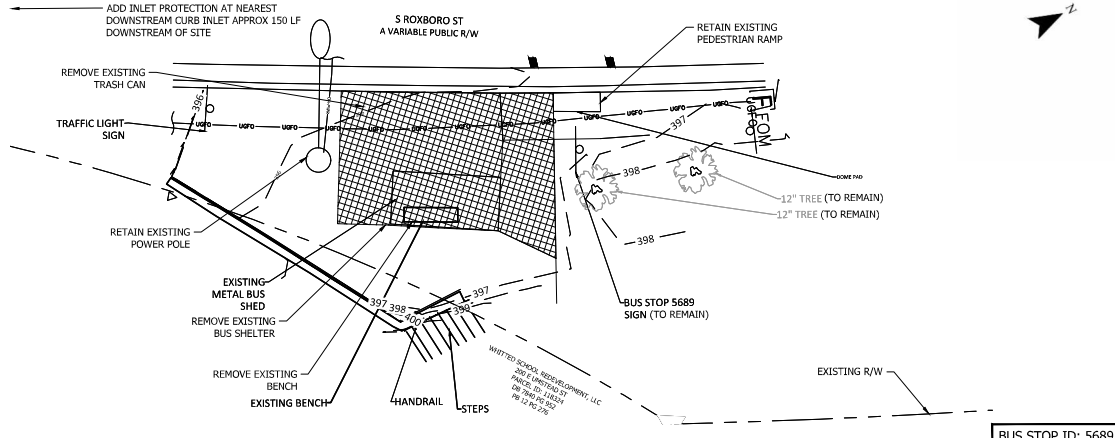
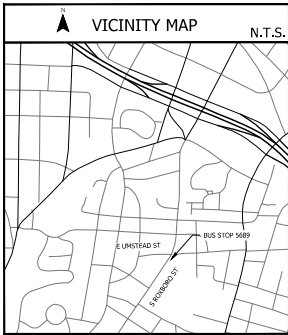

BUS STOP ID: 5689

PROPOSED PLAN

- NOTES:
- SEE GENERAL NOTES, LIST OF STANDARDS, AND DETAILS ON SHEET 02.
 - MOUNT SIGN 7'-0" ABOVE SIDEWALK, 2'-0" MIN AND 8' MAX CLEAR FROM FACE OF CURB TO EDGE OF SIGN.
 - CONTRACTOR TO RETAIN AND PROTECT EXISTING UTILITIES. ANY DAMAGE TO EXISTING UTILITIES WILL REQUIRE THE CONTRACTOR TO REPLACE THE UTILITIES AT NO ADDITIONAL COST TO THE OWNER.
 - IF ANY DAMAGE OCCURS TO ADJACENT SIDEWALK PANELS, CONTRACTOR TO REPLACE ENTIRE PANEL.

- MG = MATCH EXISTING GRADE
- PROPOSED BUS SHELTER/LANDING AREA/AMENITY PAD 6' PAD
- PROPOSED 4" CONCRETE
- PROPOSED LANDSCAPED AREA
- TC = TOP OF CURB
- BC = BOTTOM OF CURB

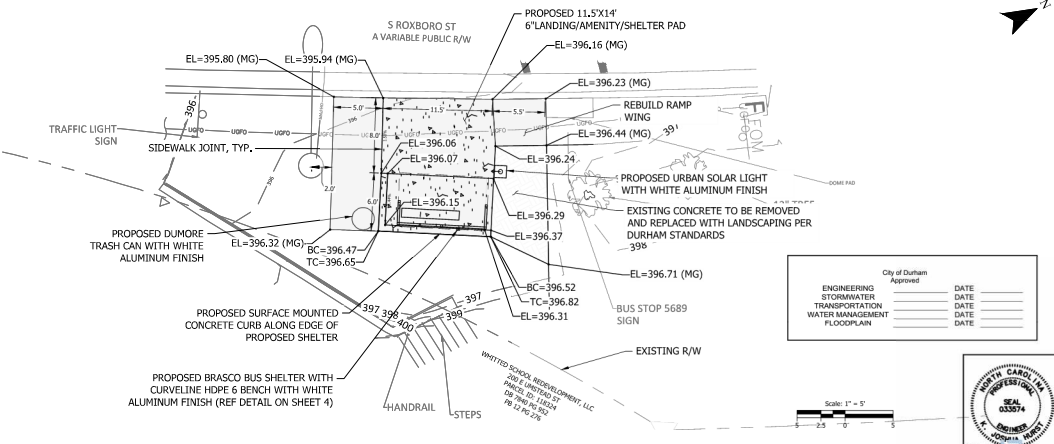
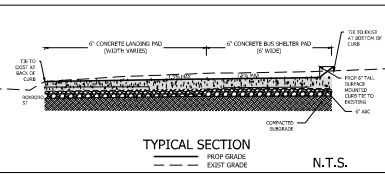

City of Durham Approved	
ENGINEERING	DATE _____
STORMWATER	DATE _____
TRANSPORTATION	DATE _____
WATER MANAGEMENT	DATE _____
FLOODPLAIN	DATE _____



Triangle Durham

KITTELSON & ASSOCIATES
 702 LORRAINE RD., SUITE 410
 DURHAM, NC 27705
 919.286.1321

NO.	DATE	REVISION

Submission Date: 08/15/24
 Project No: 26947
 Project Name: 5689 - S ROXBORO ST AT UNSTEAD ST

Bus Stop Improvements - #A-1
 Durham, NC

SHEET NO. 14

File: H:\2024\1-182-24\1-182-24.dwg - Durham Bus Stop Design\02.dwg, 08/15/24

EXISTING SURVEY/DEMOLITION PLAN

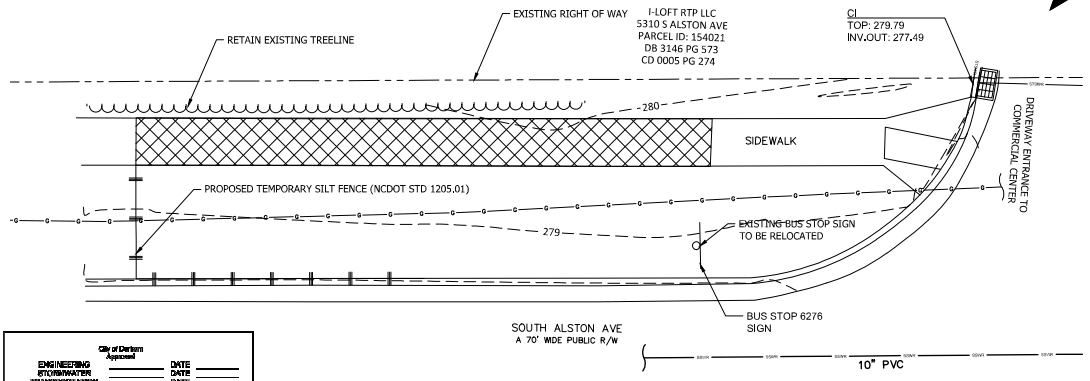
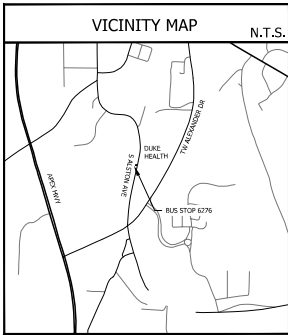

City of Durham Approval		DATE
ENGINEERING	_____	_____
STORMWATER	_____	_____
TRANSPORTATION	_____	_____
WATER MANAGEMENT	_____	_____
FLOODPLAIN	_____	_____

BUS STOP ID: 6276

PROPOSED PLAN

- NOTES:**
- SEE GENERAL NOTES, LIST OF STANDARDS, AND DETAILS ON SHEET 02.
 - MOUNT SIGN 7'-0" ABOVE SIDEWALK, 2'-0" MIN AND 8' MAX CLEAR FROM FACE OF CURB TO EDGE OF SIGN.
 - CONTRACTOR TO RETAIN AND PROTECT EXISTING UTILITIES. ANY DAMAGE TO EXISTING UTILITIES WILL REQUIRE THE CONTRACTOR TO REPLACE THE UTILITIES AT NO ADDITIONAL COST TO THE OWNER.

MG = MATCH EXISTING GRADE
 PROPOSED BUS SHELTER/LANDING AREA/AMENITY PAD 6" PAD
 PROPOSED 4" CONCRETE

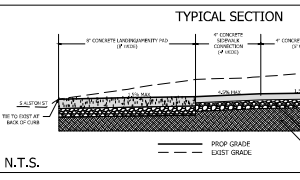
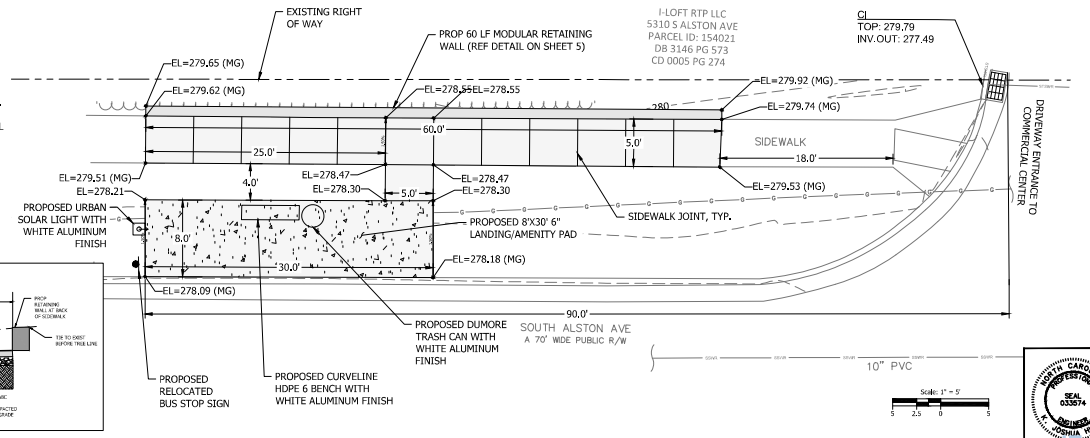

Triangle
Durham

KITTELSON & ASSOCIATES
 702 CORNELIA RD., SUITE 410
 DURHAM, NC 27705
 919.286.7321

NO.	DATE	REVISION

Submission Date: 08/15/24
 Project: GCS
 Designer: ECS
 Checker: KCH
 Project No.: 26947
Bus Stop Improvements - #A-1
 Durham, NC
 6276 - S ALSTON AVE AT DUKE HEALTH (SB)
 SHEET NO. 16

File: H:\2024\26947\A-1\26947-1.dwg
 Plot Date: 8/15/24 2:02:27 PM
 User: jk
 Plot Device: HP DesignJet 5000 Series
 Plot Style: HP-DesignJet5000.ctb
 Plot Path: H:\2024\26947\A-1\26947-1.dwg

EXISTING SURVEY/DEMOLITION PLAN

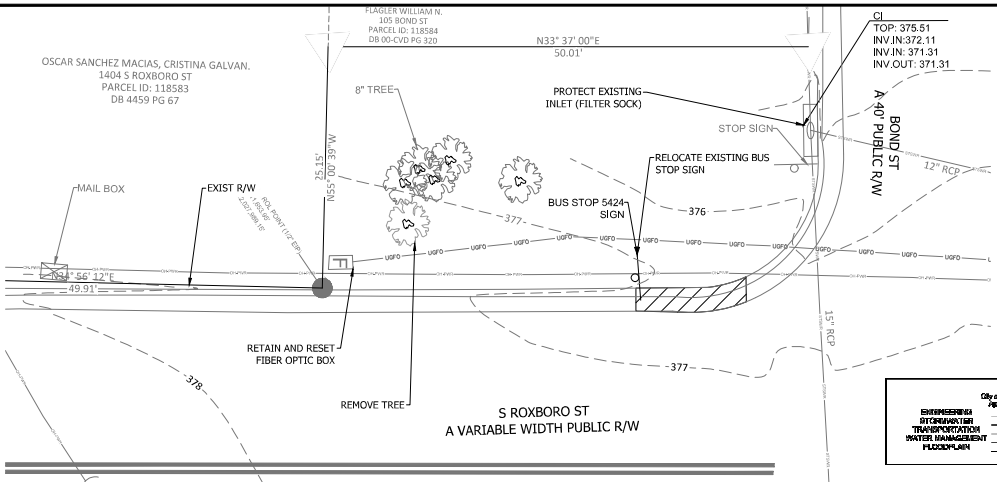
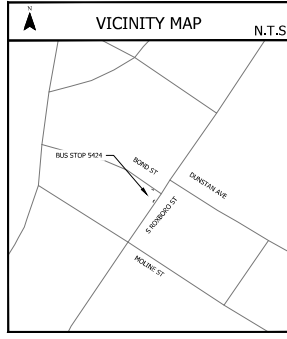

ENGINEERING	DATE
City of Durham Approved	
TRANSPORTATION	
WATER MANAGEMENT	
PLANNING	

BUS STOP ID: 5424

PROPOSED PLAN

- NOTES:**
- SEE GENERAL NOTES, LIST OF STANDARDS, AND DETAILS ON SHEET 02.
 - MOUNT SIGN 7'-0" ABOVE SIDEWALK, 2'-0" MIN AND 8" MAX CLEAR FROM FACE OF CURB TO EDGE OF SIGN.
 - CONTRACTOR TO RETAIN AND PROTECT EXISTING UTILITIES. ANY DAMAGE TO EXISTING UTILITIES WILL REQUIRE THE CONTRACTOR TO REPLACE THE UTILITIES AT NO ADDITIONAL COST TO THE OWNER.
 - IF ANY DAMAGE OCCURS TO ADJACENT SIDEWALK PANELS, CONTRACTOR TO REPLACE ENTIRE PANEL.

PROPOSED 6" CONCRETE

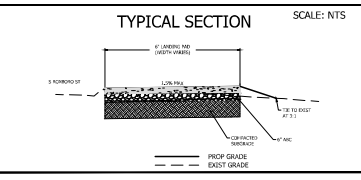
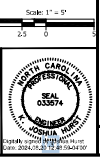
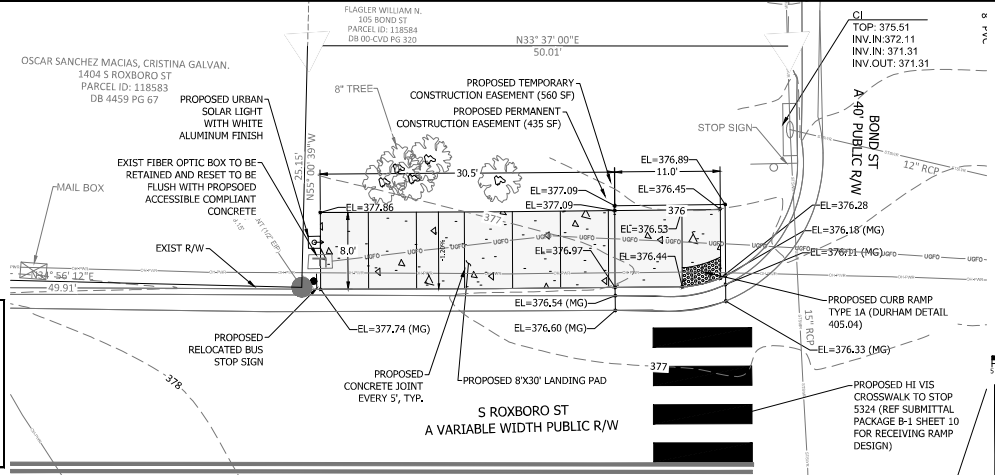

KITTLESTON & ASSOCIATES

 100 LEBLANC RD., SUITE 410

 DURHAM, NC 27701

 PROJECT NO. 26947

 SHEET NO. 17

 Submission Date: 08/20/24

 Drawn: CCS

 Checked: KJH

 Scale: 1" = 5'

EXISTING SURVEY/DEMOLITION PLAN

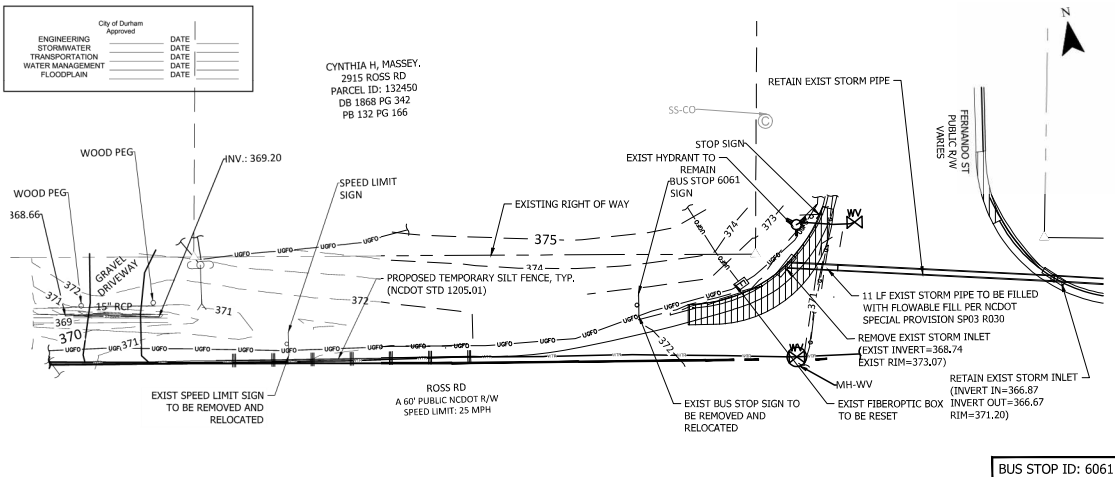
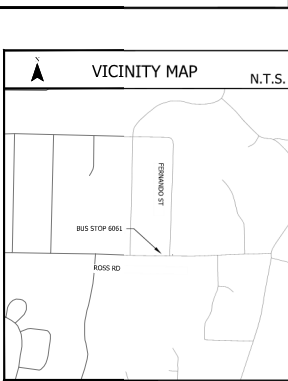

BUS STOP ID: 6061

PROPOSED PLAN

- NOTES:
- SEE GENERAL NOTES, LIST OF STANDARDS, AND DETAILS ON SHEET 02.
 - MOUNT SIGN 7'-0" ABOVE SIDEWALK, 2'-0" MIN AND 8" MAX CLEAR FROM FACE OF CURB TO EDGE OF SIGN.
 - CONTRACTOR TO RETAIN AND PROTECT EXISTING UTILITIES. ANY DAMAGE TO EXISTING UTILITIES WILL REQUIRE THE CONTRACTOR TO REPLACE THE UTILITIES AT NO ADDITIONAL COST TO THE OWNER.
 - FULL DEPTH PAVEMENT DESIGN SHALL FOLLOW THE DURHAM REFERENCE GUIDE FOR DEVELOPMENT SECTION 9. THE FULL DEPTH PAVEMENT SECTION SHALL BE AS FOLLOWS: 10 INCH ABC STONE (BASE COURSE) 3 INCH I19 (INITIAL COURSE), 2 INCH S9.5B (FINAL COURSE).



TYPICAL SECTION

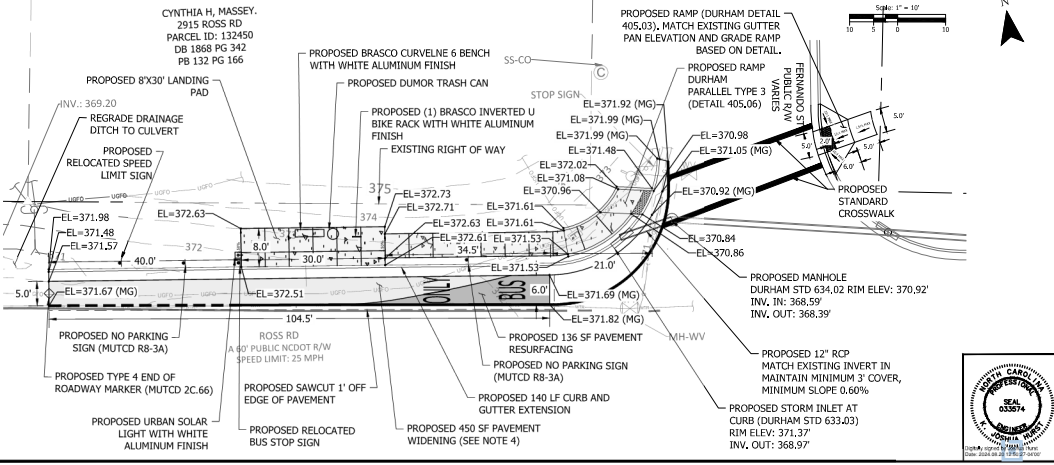
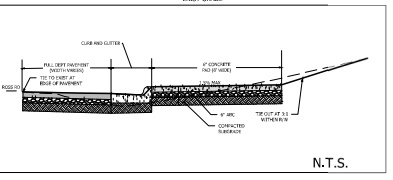

Triangle Durham
 KITTELSON & ASSOCIATES
 NC LICENSE #643196
 702 ORIELLA RD, SUITE 410
 RALEIGH, NC 27603
 PROJECT NO. 26947
 SHEET NO. 18
 Submission Date: 08/15/24
 Project: CCS
 Design: CCS
 Check: KCH
 Bus Stop Improvements - #A-1
 Durham, NC
 6061 - ROSS RD AT FERNANDO ST

GoTriangle Bus Stop Improvements - #A-1

EXHIBIT B

PROJECT SPECIAL PROVISIONS

1. SITES REQUIRING FINAL AGREEMENTS

The following improvement locations are in the process of being approved by adjacent property owners or appropriate jurisdictions but are included in this bid proposal. Approvals to begin work on these sites are expected to fall within the project duration with sufficient time to complete the work prior to the end of contract date. No work on these sites shall begin without written notification from the Engineer or Owner. Any work performed by the Contractor at these locations before their notice to proceed will be at no cost to the Owner and any work to repair unauthorized work will be at no additional cost to the Owner. Should this work not be feasible to complete within the project duration at the determination of the City, a contract change order may be provided or these sites may be removed from the work to be completed. Should the plans require changes, a revised plan sheet is to be provided and a change order may be issued based on changes to items and quantities to be constructed. No change order increases will be made for the inclusion of this work upon notice to proceed.

This list of sites is not intended to be all-inclusive, and it shall be the Contractor's responsibility to make sure the proper documents and authorized plans are received from the City and Engineer prior to beginning work at any location.

- **Site 6128 – Stadium Dr at Wyldewood Rd (Foxfire Apts)**
- **Site 6604 – Stadium Dr at Wyldewood Rd (NB)**
- **Site 5600 – Carver St at Commons Blvd (WB)**
- **Site 6366 – Carver St at Commons Blvd (EB)**
- **Site 5495 – Clarendon St at Club Blvd NW**
- **Site 5404 – E Main St at Hyde Park Ave (WB)**
- **Site 6086 – E Main St at Hyde Park Ave (EB)**
- **Site 5689 – S Roxboro St at Umstead St**
- **Site 5054 – University Dr at Larchmont Rd**
- **Site 6276 – S Alston Ave at Duke Health (SB)**
- **Site 5424 – S Roxboro St at Bond St**
- **Site 6061 – Ross Rd at Fernando St**

2. MOBILIZATION/TRAVEL TIME

Mobilization/Travel Time payment will be made by Lump Sum and is to include all mobilization of the contractor's equipment and personnel to perform the work required under this contract.

3. DEMOLITION

GoTriangle Bus Stop Improvements - #A-1

EXHIBIT B

Demolition will be completed in accordance with Section 200 of the latest version of the *NCDOT Standard Specifications for Roads and Structures*. Removal of existing benches, curb and gutter, sidewalk, asphalt pavement, pipes, trimming of trees, trees and bushes within the construction limits, amenities are included in this work. Removal of additional concrete curbs, sidewalks, or other structures to the nearest joint when within two feet of joint will be considered incidental to *Demolition* and no additional payment shall be made unless otherwise noted and approved by the Engineer.

The hauling, transport, and delivery of amenities or other items to be returned to the Owner's facilities is considered incidental to *Demolition*.

Perform clearing on this project to the limits established by "Method of Clearing - Method II" shown on Standard No. 200.02 of the *NCDOT 2024 Roadway Standard Drawings*.

Demolition payment will be made by lump sum and is to include all labor, materials, transportation, and incidentals required to suitably remove and properly haul all salvaged materials or to properly dispose of as noted on the plans.

4. MAILBOX, SIGN, AND MISCELLANEOUS APPURTENANCES MAINTENANCE

The Contractor shall be required to maintain mailboxes, signs, and all miscellaneous appurtenances impacted by the construction activities in working order for the duration of construction and as directed by the Engineer. Work on the same items shall be done in a timely manner. No separate payment for work on these items will be made as the work will be considered incidental to other items in the contract unless otherwise noted in the contract documents, including final relocation of mailboxes, signs, and other miscellaneous appurtenances

5. EARTHWORK

The work covered by this section consists of the excavation, placement, and compaction or satisfactory disposal of all materials encountered within the limits of the work necessary for the construction of the project in conformity with the lines, grades, and typical sections shown on the plans or established by the Engineer.

The Contractor shall fill areas that settle unevenly during the course of construction at no additional cost to the Owner.

UNCLASSIFIED EXCAVATION

All material excavated in order to achieve the site lines, grades, and cross sections shown on the plans shall be classified as Unclassified Excavation.

Whenever encountered during work, remove any trash and non-natural debris. Remove all roots and pieces of wood or debris larger than three (3) inches in diameter.

GoTriangle Bus Stop Improvements - #A-1

EXHIBIT B

All suitable material removed in the excavation shall be used as far as practicable in the formation of embankments, subgrades, and shoulders, and at such other places as may be indicated on the plans or directed by the Engineer. Unsuitable material and excess excavated material not required for construction of embankments shall be properly disposed of offsite at no additional cost to the Owner.

The intersection of slopes with natural ground surfaces, including the beginning and ending of cut slopes, shall be uniformly rounded as shown on the plans or as may be directed by the Engineer. Concurrent with the excavation of cuts, the Contractor shall construct intercepting berm ditches or earth berms along and on top of the cut slopes at locations shown on the plans or designated by the Engineer. All slopes shall be finished to reasonably uniform surfaces acceptable for seeding and mulching operations. All protruding roots and other objectionable vegetation shall be removed from slopes.

When the Contractor's excavation operations encounter graves, the operations shall be temporarily discontinued in the vicinity of the graves and not resumed until so directed by the Engineer.

When the Contractor's excavation operations encounter artifacts of historical or archeological significance, the operations shall be temporarily discontinued in the vicinity of the artifacts and not resumed until so directed by the Engineer. Disposition of the artifacts shall be in accordance with the requirements of the State Division of Archives and History.

A tolerance of plus or minus 0.10 foot from the established grade will be permitted in the roadbed after it has been graded to a uniform surface.

The Contractor shall be responsible during construction and until final acceptance for the maintenance of all work covered by this section.

During construction and until final acceptance, the Contractor shall shape the excavated surface to provide for the drainage of surface runoff along and throughout the length of the cut, shall construct temporary ditches, and use any other methods necessary to maintain the work covered by this section so that the work will not contribute to excessive soil erosion.

As much as practicable, the Contractor shall perform the work covered by this subsection and the construction of embankments in such a manner that cut and fill slopes will be completed to final slopes and grade in a continuous operation. The operation of removing excavation material from any cut and the placement of embankment in any fill shall be a continuous operation to completion unless otherwise permitted by the Engineer.

GoTriangle Bus Stop Improvements - #A-1

EXHIBIT B

If grading operations are suspended for any reason whatsoever, partially completed cut and fill slopes shall be brought to the required slope and the work of seeding and mulching or other required erosion control operations shall be performed.

EMBANKMENT

The work covered by this subsection consists of placing in embankments, backfills, and earth berms, suitable material excavated as previously described by these specifications in conformity with the lines, grades, and typical cross sections shown on the plans or established by the Engineer. It shall include the preparation of the areas upon which the embankment is to be constructed; the formation, compaction, stability, and maintenance of the embankment.

Before embankment construction is begun, all vegetation, debris, deleterious and unsuitable material shall be removed from the area within the limits of the embankment.

Embankment material and backfill material shall consist of clean, readily compactible earthen material with a maximum particle size of two (2) inches. Embankment material shall be free from debris, organic matter, frozen or deleterious material, and shall be approved for use by the Owner.

The embankment material shall be deposited and spread in successive, uniform, approximately horizontal layers of not more than eight (8) inches in depth, loose measurement, for the full width of the cross section, and shall be kept approximately level by the use of effective spreading equipment. Each layer of the embankment shall be thoroughly compacted as hereinafter specified. Hauling shall be distributed over the full width of the embankment, and in no case will deep ruts be allowed to form during the construction of the embankment. The embankment shall be properly drained at all times.

All embankment material shall be compacted as specified herein unless otherwise provided in the contract or directed by the Engineer. Compaction equipment used by the Contractor shall be adequate to produce the required compaction and produce a uniformly constructed embankment with all layers uniformly bound to all preceding layers.

The embankment material shall be compacted to at least 95% of the maximum dry density obtained by compacting a sample of the material in accordance with ASTM D-698, except for the upper one foot of subbase below pavement base, which shall be compacted to at least 100% of the maximum dry density obtained by compacting a sample in accordance with ASTM D-698. Embankment materials shall be compacted at a moisture content satisfactory to the Engineer, which shall be approximately that required to produce the maximum dry density. The Contractor shall dry or add moisture to the embankment material when required to provide a uniformly compacted and stable embankment.

GoTriangle Bus Stop Improvements - #A-1

EXHIBIT B

Backfill materials placed around and over pipe culverts, box culverts, and arch culverts, and embankment materials placed around other structures, shall be clean select material. The material shall be placed and compacted in a manner, which will avoid unbalanced loading and will not produce undue stress on the structure. Such embankments shall be placed in loose layers not to exceed six (6) inches in depth and each layer shall be thoroughly compacted as hereinafter specified. All pipe culverts, box culverts, and arch culverts, after being backfilled as specified in this subsection, shall be protected by a three (3) foot cover of fill at any time that heavy hauling equipment is permitted to cross during construction of the roadway. Any damage or displacement to culverts or other structures due to the Contractor's operation shall be corrected or repaired by the Contractor prior to final acceptance at no cost to the Owner.

The Contractor shall be responsible during construction and until final acceptance for the maintenance of all embankments made under the contract.

During construction and until final acceptance, the Contractor shall construct temporary or permanent earth berms along the outer edges of the top surface of the embankment, construct temporary ditches, shape the embankment surface to provide for the drainage of surface runoff along and throughout the length of the embankments, and use any other methods necessary to maintain the work covered by this section so that the work will not contribute to excessive soil erosion.

The contractor shall replace, at no cost to the Owner, any portion of embankments, which have become displaced or damaged due to carelessness or neglect on the part of the Contractor. Where the work has been properly constructed, completely drained, and properly maintained, and damage occurs due to natural causes, the Contractor will be paid at the contract unit price for the excavated material required to make necessary repairs to such damage. Measurements of quantities must be performed and approved prior to commencement of work.

All embankments shall be brought to the grade shown on the plans, or established by the Engineer, prior to final inspection and acceptance by the Engineer.

UNDERCUT EXCAVATION

The work covered by this subsection consists of the excavation, placement, and compaction and/or satisfactory disposal of materials removed from a location below the finished graded cross section.

When the Engineer determines that the natural soil materials are undesirable in their location or condition, the Engineer may require the Contractor to remove this undesirable material and backfill with approved material properly compacted.

GoTriangle Bus Stop Improvements - #A-1

EXHIBIT B

Where undercutting is required adjacent to or beneath the location of a proposed drainage structure, undercut and backfill shall be done over a sufficient distance adjacent to the installation to prevent future operations from disturbing the completed drainage structure.

All materials removed in the work of undercut excavation will be classified by the Engineer as either suitable for use without excessive manipulation and utilized by the Contractor elsewhere in the work, or unsuitable for further use and disposed of by the Contractor as directed by the Engineer.

The Contractor shall conduct undercut operations in such a way that the Engineer can take the necessary measurements before any backfill is placed.

Backfill in undercut areas shall be placed as a continuous operation along with the undercutting operation. Backfill material shall not be placed in water unless otherwise permitted by the Engineer.

BORROW EXCAVATION

The work covered by this subsection consists of the excavation of approved material from borrow sources and the hauling and placing of this material as required on the plans or as directed by the Engineer. It shall also include the satisfactory disposal of any material from the borrow source which is not suitable for use. All work covered by this subsection shall be in accordance with Section 230 of the latest version of the *NCDOT Standard Specifications for Roads and Structures*.

PAYMENT

Earthwork payment will be made by Lump Sum and to include all labor, materials, transportation, and incidentals required to perform the work described within this section including, but not limited to, excavation, removal and disposal of undesirable material, backfilling with suitable material, constructing embankments necessary to achieve the grades indicated on the plans, and maintaining the work.

GoTriangle Bus Stop Improvements - #A-1

EXHIBIT B

6. EROSION CONTROL

Temporary and permanent erosion control measures shall be furnished, constructed, maintained, and removed in accordance with the current NCDOT standard specifications with the exception of Method of Measurement and Payment. Erosion control measures shall be provided for all land disturbing activities in accordance with the Contract Documents and/or an erosion control plan approved by the North Carolina Department of Environment and Natural Resources (NCDENR). Temporary measures shall be installed by the Contractor, then inspected by the Inspector for compliance prior to any land disturbing activity. The inspection and approval process shall be required on each phase of construction. All permanent erosion control measures shall be incorporated into the work at the earliest practical time. All temporary measures shall be maintained until the permanent measures have taken effect. Temporary and permanent measures shall be coordinated to provide effective and continuous erosion control throughout the construction and post-construction period to minimize siltation of streams, lakes, reservoirs, and other impoundments, ground surfaces, and other property. These measures shall remain in effect until final approval for removal is given by the Inspector and/or the NCDENR at which time the Contractor shall remove all temporary erosion control measures at no additional cost to the Owner.

The Contractor shall be familiar with the applicable provisions of the Sedimentation Pollution Control Act of 1973, General Statutes, Chapter 113A, Article 4. The Contractor shall be responsible for incorporating conservation procedures necessary to comply with this act in minimizing erosion and sediment pollution associated with the construction of this project as directed by the Engineer.

The Contractor shall be financially responsible for any and all fines that result from the Contractor's failure to install and/or maintain erosion control measures in accordance with the Contract Documents.

The Contractor shall check all erosion and sediment control measures for stability and operation following each rainfall event, and no less than once per week. The Contractor shall make any needed repairs immediately to maintain all control measures as designed.

The Contractor shall clean out all sediment trapping devices when the device reaches 50% trap capacity and shall dispose of the sediment by spreading on the site in a protected area or by hauling away if not suitable for fill at no additional cost to the Owner.

TEMPORARY MEASURES

Temporary Silt Fence shall be installed around inlets, at the toe of all fill slopes, and any other necessary locations as shown on the plans and as directed by the Engineer. Silt fence shall be erected in accordance with the latest version of the *NCDOT Standard Specifications for Roads and Structures*.

GoTriangle Bus Stop Improvements - #A-1

EXHIBIT B

Inlet Protection shall be installed around inlets and any other necessary locations as shown on the plans and as directed by the Engineer. Inlet protection shall be erected in accordance with the latest version of the *NCDOT Standard Specifications for Roads and Structures*.

Diversion Ditches shall be installed at the top of cut and fill slopes and any other necessary locations as shown on the plans and as directed by the Engineer. Diversion ditches shall be installed in accordance with the latest version of the *NCDOT Standard Specifications for Roads and Structures*.

Tree Protection Fence shall be installed around the drip line of trees in the construction work area as shown on the plans and as directed by the Engineer. The tree protection fence shall be installed in such a manner that it prevents all construction activities from encroaching into the area inside the drip line of the tree. The material and installation specifications for the tree protection fence shall be approved for use by the Engineer prior to installation.

Construction Entrances shall be installed at all points of access to the construction site. Any access point, which does not have a construction entrance, shall be barricaded to prevent its use. Construction entrances shall be installed in accordance with the latest version of the *NCDOT Standard Specifications for Roads and Structures*. Construction entrances shall be included in the unit bid price for "Mobilization."

Sediment and Filter Basins shall be installed at all points where accumulated runoff is released to natural drainage channels as shown on the plans and as directed by the Engineer. Sediment pits and filter basins shall be sized to hold 1800 cubic feet of sediment for every acre of denuded area tributary to the structure. Sediment and filter basins shall be installed in accordance with the latest version of the *NCDOT Standard Specifications for Roads and Structures*.

Catch Basin Risers/Filters shall be installed at proposed catch basin locations or at other necessary locations as shown on the plans and as directed by the Engineer. Catch basin risers/filters shall be erected in accordance with the latest version of the *NCDOT Standard Specifications for Roads and Structures*.

Check Dams shall be installed in ditches any and at other necessary locations as shown on the plans and as directed by the Engineer. Check dams shall be erected in accordance with the latest version of the *NCDOT Standard Specifications for Roads and Structures*.

Matting for erosion control shall be jute matting or excelsior matting. Matting for erosion control shall not be dyed, bleached, or otherwise treated in a manner that will result in toxicity to vegetation.

GoTriangle Bus Stop Improvements - #A-1

EXHIBIT B

Jute Matting: Jute matting shall be of a uniform open plain weave of single jute yarn, forty-eight (48) inches in width, plus or minus one (1) inch. The yarn shall be of a loosely twisted construction and shall not vary in thickness by more than one-half its normal diameter. There shall be 78 warp ends, plus or minus 2, per linear yard; and the weight shall average 1.22 pounds per linear yard of the matting with a tolerance of plus or minus 5 percent.

Excelsior Matting: Excelsior matting shall consist of a machine-produced mat of curled wood excelsior at least 47 inches in width. The mat shall weigh 0.975 pounds per square yard with a tolerance of plus or minus 10 percent. At least 80% of the individual excelsior fibers shall be 6 inches or more in length. The excelsior fibers shall be evenly distributed over the entire area of the blanket. One side of the excelsior matting shall be covered with a woven fabric of twisted paper cord or cotton cord, or with an extruded plastic mesh. The mesh size for either the fabric or plastic mesh shall be a minimum of 1" x 1" and a maximum of 1-1/2" x 3".

Wire Staples: Staples shall be machine-made of No. 11 gage new steel wire formed into a "U" shape. The size when formed shall be not less than 6 inches in length with a throat of not less than 1 inch in width.

Erosion Control payment will be made by Lump Sum and will include all work covered by this section including, but not limited to, the labor, equipment, and materials for furnishing, installing, and removing all temporary erosion control measures indicated on the plans, and maintenance of the work throughout the life of the project as required by the Inspector.

GoTriangle Bus Stop Improvements - #A-1

EXHIBIT B

7. TEMPORARY TRAFFIC CONTROL

The work covered by this section consists of the furnishing, erecting, maintaining, relocating, and removing traffic control devices in accordance with the Contract as well as the following sections from the latest version of the *NCDOT Standard Specifications for Roads and Structures*, with the exception of the method of payment, or as directed by the Engineer:

Section 1101	Work Zone Traffic Control General Requirements
Section 1105	Work Zone Traffic Control Devices
Section 1110	Work Zone Signs
Section 1115	Flashing Arrow Boards
Section 1130	Drums
Section 1135	Cones
Section 1145	Barricades
Section 1150	Flaggers

Temporary Traffic Control payment will be made by Lump Sum and is to include all work covered by these sections including furnishing, erecting, relocating, maintain, and removing any and/or all temporary traffic control devices.

8. THERMOPLASTIC & PAINT PAVEMENT MARKINGS

All work associated with the furnishing, installing, and removing of pavement markings shall be performed in accordance with the Contract as well as the following sections of the *NCDOT Standard Specifications for Roads and Structures* with the exception of the method of payment, or as directed by the Engineer:

Section 1205	Pavement Marking General Requirements
--------------	---------------------------------------

In the case pavement markings called for on plans are not covered by *NCDOT Standard Specifications for Roads and Structures*, the Contractor shall refer to the MUTCD and any interim approvals as applicable.

Pavement Markings payment will be made by Lump Sum or as otherwise indicated in the itemized proposal and is to include all work covered by these sections including furnishing, installing, and removing pavement markings.

Pavement markings are itemized as shown below and reflected in the cost estimate:

- THERMOPLASTIC PVT MKG LINES (24", 90 MILS)
- THERMOPLASTIC PVT MKG LINES (6", 90 MILS)
- THERMOPLASTIC PVT MKG LINES (12", 90 MILS)
- THERMOPLASTIC PVT SYMBOL 90 MILS
- THERMOPLASTIC PVT MKG CHARACTER, 90 MILS
- GREEN PAINT

GoTriangle Bus Stop Improvements - #A-1

EXHIBIT B

9. GRASS SOD/MULCH

Sod is to be placed in all disturbed areas within the construction limits as shown on the plans.

The Contractor shall substitute mulch for sod in areas as indicated on the plans to match existing site conditions. Mulch shall be placed at a minimum of 4" thick to match the existing conditions or as called for in the plans.

Lay sod as soon as possible after it has been harvested to prevent injury. Sod should be installed within 24 hours of delivery. While installing, take action as necessary to prevent heat buildup within the unlaied sod. Plan to unstack and unroll the sod if it cannot be laid within 48 hours. Soil should be moist (but not overly wet) before laying sod. Irrigating the soil several days before delivery is often adequate.

Start sodding from a straight edge (driveway or sidewalk) and butt strips together, staggering them in a brick-like pattern. Avoid stretching sod. Use a knife or sharp spade for trimming to fit irregularly shaped areas. Lay sod lengthwise across the face of slopes and peg or stake the pieces to prevent slippage. After the sod has been placed, roll the lawn to ensure good sod-to-soil contact.

Water sod immediately after installation. Soak sod thoroughly enough to penetrate soil below the newly installed sod to a minimum depth of two (2) inches. Contractor is responsible for insuring adequacy of water supply. The Contractor shall provide any necessary temporary means to properly water sod, including temporary pumps and sprinklers. Proper irrigation shall be required by the Contractor until the project has been inspected and is accepted by the Owner.

In some cases, sod can be laid in space planting "semi-checkerboard" fashion in order to lower costs. This method is described here assuming that the sod is cut into the standard 18 in. x 24 in. size. The first piece of sod is laid with the narrow side flush to a straight edge. This will start a row that is 24 in. wide. The next piece of sod is laid likewise but it is spaced 9 in. away and parallel to the first piece along the longer side. This is continued to make the first row. The next row is laid flush with the previous and in the same fashion except it laid offset by 9 inches, i.e. laid beginning at the centerline of the first piece of sod in the previous row. Subsequent rows are laid in this alternating pattern.

Upon completion of work, the Contractor shall remove from the site all equipment and other articles used. All excess soil, stone, and debris shall be removed and legally disposed of at no additional cost to the Owner. All work areas shall be left in a clean and neat condition. All damage to existing construction caused by landscaping operations shall be repaired to the satisfaction of the Owner at the Contractor's expense.

GoTriangle Bus Stop Improvements - #A-1

EXHIBIT B

The Contractor will be responsible for watering grass for a two (2) week period after installation. The Contractor shall notify Engineer once grass is installed to start the two-week period. The Contractor is to replace any dead grass at the direction of the Engineer and water for an additional two weeks at no additional cost to the Owner.

LAWN SEEDING (Cool- and Warm-Season Grasses)				
Typical Planting Rate/1,000 sq. ft.				
Lawn Grass	Planting Dates¹	Seeds²	Space Planting³	Sprigging⁴
Tall fescue	March 1 to Oct. 15 (Aug. 15 to Oct. 1 optimum)	6	-	-
Tall fescue/annual (winter) rye	Oct. 15 to March 1	6 fescue 1 rye		
Bermudagrass(seed)	Apr. 1 to Aug. 15	1 to 2	-	-
Bermudagrass (vegetative)	Apr. 15 to Aug. 30	-	5 ⁴	5
Centipedegrass	March to July	0.25 to 0.50	5 ⁴	-
Zoysiagrass	April to July	-	5 ⁴	5
St. Augustinegrass	Apr. to July	-	5 ⁴	-

Notes:

- 1 Sod consisting of cool-season grasses can be installed anytime the ground is not frozen. Sod consisting of warm- season grasses can be installed as long as soil temperature exceeds 55° F. (typically April 15 to Oct. 1)
- 2 Pounds of seed per 1,000 sq. ft.
- 3 Square yards of turf cut into 2-inch centers to plant 1,000 sq. ft.
- 4 Bushels of sprigs per 1,000 sq. ft. (1 sq. yd. of turf pulled apart is equivalent to 1 bushel of sprigs.)

Grass Sod/Mulch payment will be made at the unit price per square foot or as indicated in the itemized proposal of disturbed areas shown on the plans and as indicated on the itemized proposal including, but not limited to, all equipment, labor, materials, watering and incidentals to install and maintain the sod and mulch as directed.

Watering will be considered incidental to *Grass Sod/Mulch*. The Contractor is to replace any dead grass at the direction of the Engineer and water for an additional two weeks at no additional cost to the Owner. No direct payment will be made for areas outside of the construction limits shown on the plans that have been disturbed or damaged.

GoTriangle Bus Stop Improvements - #A-1

EXHIBIT B

10. ASPHALT PAVEMENT REPAIR PATCH

Where it is necessary to open cut along or across streets with asphalt surfaces and where existing asphalt is disturbed by the removal of existing pavement or by the addition of proposed pavement, the pavement shall be replaced in accordance with City of Durham Standard Detail 408.01, or with seven (7) inches of Superpave – Asphalt Concrete Intermediate Course: Type I19.0C, and two (2) inches of Superpave – Asphalt Concrete Surface Course: Type S9.5C, or as directed by the Engineer. Use of different sections are to be at locations as identified on the plans or as directed by the engineer. The thickness of the replacement material shall be sufficient to provide a base and surface of equivalent strength to the undisturbed base and surface. The replaced pavement shall meet all applicable material and installation specifications outlined in the latest version of the *NCDOT Standard Specifications for Roads and Structures*.

Asphalt Pavement Repair Patch payment will be made at the unit price per ton or as otherwise indicated on the itemized proposal of asphalt material required to repair disturbed asphalt. The unit price will include all pavement repairs, both temporary and permanent, furnishing, hauling, placing, and shaping the asphalt pavement to produce a uniform, smooth driving surface. No additional payments will be issued to repair pavement damaged by the Contractor outside of the limits of existing asphalt adjacent to removal and replacement of existing pavement or adjacent to the addition of new pavement.

11. MILL ASPHALT PAVEMENT, -“ DEPTH

Mill Asphalt Pavement, -“ Depth will be constructed in accordance to Section 607 of the latest version of the *NCDOT Standard Specifications for Roads and Structures* at the specified thickness and as shown on the plans.

Mill Asphalt Pavement, -“ Depth payment will be made at the unit price per square foot at the specified thickness or as otherwise indicated in the itemized proposal and will include the labor, hauling, materials, and all other miscellaneous items needed to mill and remove the thickness of asphalt specified and prepare the area for other construction items.

12. ASPHALT PAVEMENT

All asphalt pavement will be installed in accordance to Sections 609 & 610 of the latest version of the *NCDOT Standard Specifications for Roads and Structures* with the specified mix types and thicknesses as shown on the plans and typical sections. The pavement mixes shall meet all applicable material and installation specifications outlined in the latest version of the *NCDOT Standard Specifications for Roads and Structures*. Contractor to provide NCDOT approved mix designs prior to paving.

GoTriangle Bus Stop Improvements - #A-1

EXHIBIT B

Full Depth Asphalt Pavement, -“ will include all the mix types at the specified thicknesses for each layer to the total depth specified.

Full Depth Asphalt Pavement, -“ payment will be made at the unit price per square foot of the specified thicknesses and mix types installed and accepted or as otherwise indicated in the itemized proposal and will include the labor, materials, asphalt binder, and all other miscellaneous items needed to install the asphalt. See Section 610 of the latest version of the *NCDOT Standard Specifications for Roads and Structures* for full description of all items included.

Var. Depth, (Mix Type) will be made at the unit price per square foot of the variable depth of the specified mix type installed and accepted or as otherwise indicated in the itemized proposal and will include the labor, materials, asphalt binder, and all other miscellaneous items needed to install the asphalt. See Section 610 of the latest version of the *NCDOT Standard Specifications for Roads and Structures* for full description of all items included.

13.-” CONCRETE SIDEWALK

-” *Concrete Sidewalk* will be constructed in accordance to Section 848 of the latest version of the *NCDOT Standard Specifications for Roads and Structures* at the specified thickness and as shown on the plans with compacted subgrade.

-” *Concrete Sidewalk* payment will be made at the unit price per square foot at the specified thickness or as otherwise indicated in the itemized proposal and will include the labor, materials, compaction of subgrade, and all other miscellaneous items needed to construct the sidewalk.

14.-” CONCRETE PAD

-” *Shelter Pad* will be constructed per NCDOT Section 848 and as shown on the plans. Where called for, 6” of compacted aggregate base course is to be provided underneath the proposed pad with a minimum of 12” width of aggregate base course around the perimeter of the pad.

Where required, woven wire fabric sheets shall be placed within the shelter pad per the details provided in the plans and installed on chairs.

Where required, steel rebar shall be placed within the shelter pad per the details provided in the plans.

-” *Shelter Pad* payment will be made at the unit price per square foot of concrete pad installed and approved at the specified thickness or as otherwise indicated in the itemized proposal and will include the labor, materials, aggregate base course, woven

GoTriangle Bus Stop Improvements - #A-1

EXHIBIT B

wire fabric, rebar, compaction of subgrade, and all other miscellaneous items needed to construct the shelter pad.

15.-" CONCRETE DRIVEWAY

- " *Concrete Driveway* will be constructed in accordance to Section 848 of the latest version of the *NCDOT Standard Specifications for Roads and Structures* at the specified thickness and as shown on the plans with compacted subgrade.

- " *Concrete Driveway* payment will be made at the unit price per square foot at the specified thickness or as otherwise indicated in the itemized proposal and will include the labor, materials, compaction of subgrade, and all other miscellaneous items needed to construct the driveway.

16.-' -" CURB & GUTTER

- ' - " *Curb & Gutter* will be constructed in accordance to Section 846 of the latest version of the *NCDOT Standard Specifications for Roads and Structures*. Asphalt base course / ABC, as indicated on the plans, under the curb shall be installed per the current NCDOT standards and specifications at the thicknesses shown on the plans or as directed by the Engineer. Asphalt under the curb will extend behind the back of the proposed curb a minimum of 6" and ABC a minimum of 12".

- ' - " *Curb & Gutter* payment will be made at the unit price per linear foot at the specified size or as otherwise indicated in the itemized proposal and will include the labor, materials, asphalt or stone base, and all other miscellaneous items needed to construct the curb & gutter. Payment for this item will not be made until complete, including backfilling, until inspected and accepted by the Owner.

17.-" X -" CONCRETE CURB

- " x - " *Concrete Curb* will be constructed in accordance to Section 846 of the latest version of the *NCDOT Standard Specifications for Roads and Structures*. Asphalt base course / ABC, as indicated on the plans, under the curb shall be installed per the current NCDOT standards and specifications at the thicknesses shown on the plans or as directed by the Engineer. Asphalt under the curb will extend behind the back of the proposed curb a minimum of 6" and ABC a minimum of 12".

- " x - " *Concrete Curb* payment will be made at the unit price per linear foot at the specified size or as otherwise indicated in the itemized proposal and will include the labor, materials, asphalt or stone base, and all other miscellaneous items needed to construct the curb & gutter. Payment for this item will not be made until complete, including backfilling, until inspected and accepted by the Owner.

GoTriangle Bus Stop Improvements - #A-1

EXHIBIT B

18. SURFACE MOUNTED CONCRETE CURB

Surface Mounted Concrete Curb will be constructed in accordance to Section 848 of the *NCDOT Standard Specifications for Roads and Structures* and as shown on the plans on top of the proposed concrete pad or sidewalk sections. Heights of such curb may vary up to 12" measured from the top of the adjoining concrete pad or sidewalk section. Reinforcement steel "U"-bars shall be furnished and in accordance with Section 1070 of the *NCDOT Standard Specifications for Roads and Structures* and spaced as shown on the details or as directed by the Engineer.

Surface Mounted Concrete Curb payment will be made at the unit price per linear foot measured along the top, back of curb approved by the Engineer or as otherwise indicated in the itemized proposal and will include the labor, materials, reinforcement steel, and all other miscellaneous items needed to construct and install the curb to proposed concrete. No variance in payment will be made based on variable height of curbs shown on the plans up to 12" tall.

19. BRICK PAVERS

The Contactor is to furnish and install brick pavers as shown on the plans and in accordance with City of Durham Standard Detail Drawings 406.04, 406.05, 406.06, or other details shown on the plans as applicable. The Contractor is responsible for furnishing brick pavers that match brick in the existing vicinity unless directed otherwise by the Engineer.

The Contract is to provide a submittal of the proposed brick material for installation to the Engineer for review and approval prior to installation.

Brick Pavers payment will be made at the unit price per square feet of the brick pavers installed and approved or as otherwise indicated in the itemized proposal and will include the labor, materials, aggregate base course, compacting sand, galvanized stakes, furnishing brick pavers and all other miscellaneous items needed to install the brick pavers.

20. RETROFIT CURB RAMP

Retrofit Curb Ramps will be constructed per section 848 of the latest version of the *NCDOT Standard Specifications*.

Retrofit Curb Ramp payment will be made in accordance with Section 848-4 (see "Retrofit Existing Curb Ramps") of the latest version of the *NCDOT Standard Specifications for Roads and Structures*.

21. CONCRETE CURB RAMPS

GoTriangle Bus Stop Improvements - #A-1

EXHIBIT B

Concrete Curb Ramps will be constructed in accordance to Section 848 of the latest version of the *NCDOT Standard Specifications for Roads and Structures*.

Concrete Curb Ramps payment will be made at the unit price per each curb ramp satisfactorily installed or as otherwise indicated in the itemized proposal and will include the labor, materials, excavation and backfilling, sawing the existing sidewalk or driveway, furnishing and placing concrete, curb and gutter, constructing and sealing joints and furnishing and installing truncated domes, and all other miscellaneous items needed to construct the curb ramp. Pay limits for ramps will be as specified on the details provided in the plans.

22. MODULAR RETAINING WALL

Modular Retaining Wall will be constructed in accordance to Section 6-7 of the *NCDOT Roadway Design Manual* and as shown on the plans. Heights of such curb may vary up to 2'-6" measured from the top of the adjoining concrete pad or sidewalk section. *Modular Retaining Wall* will follow "Prefabricated Modular Gravity Wall" detail in plan set.

Modular Retaining Wall payment will be made at the unit price per square foot measured along the top, back of wall and the height of the wall approved by the Engineer or as otherwise indicated in the itemized proposal and will include the labor, materials, reinforcement steel, and all other miscellaneous items needed to construct and install the wall.

GoTriangle Bus Stop Improvements - #A-1

EXHIBIT B

23. INSTALL SHELTERS, BENCHES, AND OTHER AMENITIES

The Owner has purchased all amenities (shelters, benches, trash cans, etc.) to be used for this project unless otherwise noted in the plans or contract documents. The Contractor will pick-up, transport, and install amenities at each site as called out on the plans. The amenities will be located on the Owner's property at the Raleigh GoTriangle warehouse at 324 W Lane Street, Raleigh. The Contractor will sign for amenities prior to leaving the Owner's storage facility indicating the condition of the amenities. The contractor will also be responsible for hauling away and disposing of any crates or pallet/packing materials off-site in a legal manner. Amenities will be assembled and installed per manufacturer's recommendations using an anchoring system. The Contractor shall provide anchor units to install amenities on concrete per manufacturer's requirements. The Contractor will coordinate all efforts with the Owner. The Contractor will be responsible for any damages to amenities once they leave the Owner's storage facility. The Contractor is to keep the storage facility clean at all times, including removing and disposing properly offsite of trash and sawdust, metal filings and other detritus created.

Install Bus Shelter and Amenities payment will be made at the unit price per each bus shelter to be installed or as otherwise indicated on the itemized proposal and shall include all transportation, assembly, installation and incidentals required to install the shelter, bench, and other amenities (trash cans, charging stations, etc.) as shown on the plans.

Install Bench and Amenities payment will be made at the unit price per each bench to be installed or as otherwise indicated on the itemized proposal and shall include all transportation, assembly, installation and incidentals required to install the bench, and other amenities (trash cans, charging stations, etc.) as shown on the plans.

Install Simme-seat and Amenities payment will be made at the unit price per each Simme-seat to be installed or as otherwise indicated on the itemized proposal and shall include all transportation, assembly, installation and incidentals required to install the Simme-seat and other amenities (trash cans, charging stations, etc.) as shown on the plans.

Trash cans installed at sites with no other amenity will be considered incidental to the overall contract.

GoTriangle Bus Stop Improvements - #A-1

EXHIBIT B

24. AMENITY ITEMS & MODELS TO BE INSTALLED

The following table is a report of the amenities to be installed per the specifications of this contract. The model of amenities to be installed at any site is subject to change upon Owner and Engineer discretion prior to installation work by the Contractor at each location.

Site #	Shelter Model	Bench Model	Receptacle Model
6128	-	Brasco (White Aluminum)	Dumor (White Aluminum)
6604	-	Brasco (White Aluminum)	Dumor (White Aluminum)
5600	Brasco (White Aluminum)	Brasco (White Aluminum)	Dumor (White Aluminum)
6366	Brasco (White Aluminum)	Brasco (White Aluminum)	Dumor (White Aluminum)
5495	-	Brasco (White Aluminum)	Dumor (White Aluminum)
5404	-	Brasco (White Aluminum)	Dumor (White Aluminum)
6086	-	Brasco (White Aluminum)	Dumor (White Aluminum)
5689	Brasco (White Aluminum)	Brasco (White Aluminum)	Dumor (White Aluminum)
5054	-	Brasco (White Aluminum)	Dumor (White Aluminum)
6276	-	Brasco (White Aluminum)	Dumor (White Aluminum)
5424	-	-	-
6061	-	Brasco (White Aluminum)	Dumor (White Aluminum)

GoTriangle Bus Stop Improvements - #A-1

EXHIBIT B

25. INSTALL BIKE RACKS

The Contractor is to install bike racks in accordance with the manufacturer details and as shown on the plans. The Contractor is to coordinate with the Owner to pick-up and transport bike racks from the Owner's storage location to the locations required for installation. The bike racks are to be assembled and installed per manufacturer's recommendations.

The Contractor shall provide required anchor units to install the bike rack on concrete per manufacturer's requirements. The Contractor shall coordinate the color and style of the bike racks to be installed at each location with the Owner prior to installation.

Install Bike Racks payment will be made at the unit price per each bike rack installed or as otherwise indicated on the itemized proposal and shall include all transportation, assembly, coordination with Owner, installation and incidentals required to install the bike racks as shown on the plans.

26. INSTALL BUS STOP SECURITY LIGHTING SYSTEM

The Contractor is to install bus stop security lighting systems in accordance with the manufacturer details and as shown on the plans. The Contractor is to coordinate with the Owner to pick-up and transport the lighting systems from the Owner's storage location to the locations required for installation. The lighting systems are to be assembled and installed per manufacturer's recommendations.

Bus stop security lighting systems are to be installed on new 12-gauge galvanized steel square tube posts, at the size indicated by the manufacturer or as directed by the Engineer or as otherwise required by the manufacturer. Lighting systems and posts shall be installed to the heights specified by the manufacturer. New sign post installations and locations with bus stop security lighting systems shall be smooth wall or "Telespar Qwik-Punch" with knockouts square tube signs, or equivalent approved by the Owner. All sign posts used shall meet the requirements of Section 1094 of the latest version of the NCDOT Standard Specification for Roads and Structures.

Installation of the lighting system will also include the installation of push buttons and wiring provided and required by the manufacturer.

Install Bus Stop Security Lighting System payment will be made per each lighting system satisfactorily installed and will include, but is not limited to, furnishing of the lighting system, coordination with the Owner for approval of products to be used, new square tube sign posts, installation, installation of push buttons, equipment, labor, and materials including bolts, fabrication, and machine work and any incidentals required to satisfactorily install the lighting system.

GoTriangle Bus Stop Improvements - #A-1

EXHIBIT B

27. PEDESTRIAN SAFETY RAIL AND HANDRAIL

The Contractor is to furnish and install pedestrian safety rails and handrails at the size, height, locations, and of the materials specified in the plans. The pipe shall be 1.5" diameter galvanized schedule 40 steel or 1.5" aluminum pipe with 0.145" wall thickness or as otherwise approved by the Engineer. Footings for the rail are to be constructed continuously with adjacent concrete unless otherwise noted on the plans or as approved by the Engineer.

Where proposed rail is to attach to existing rails shown on the plans, the Contractor should furnish and install pedestrian safety and handrails that match the existing rails.

The Contractor is to provide a construction drawing submittal of the rails to be furnished to the Engineer for review and approval prior to installation.

Repair of galvanizing of the proposed handrail and safety rails shall be completed in accordance with Section 1076 of the latest version of the *NCDOT Standard Specifications for Roads and Structures*.

Pedestrian Safety Rail payment will be paid as the actual number of linear feet of safety rail installed and approved or as otherwise indicated in the itemized proposal and will include the labor, materials, fabrication, furnishing, installing, painting, concrete footings and all other miscellaneous items needed to satisfactorily install the safety rail. Measurement for *Pedestrian Safety Rail* will be made along the top of rail to the nearest whole foot.

Pedestrian Handrail payment will be paid as the actual number of linear feet of safety rail installed and approved or as otherwise indicated in the itemized proposal and will include the labor, materials, fabrication, furnishing, installing, painting, concrete footings and all other miscellaneous items needed to satisfactorily install the safety rail. Measurement for *Pedestrian Handrail* will be made along the top of rail to the nearest whole foot.

GoTriangle Bus Stop Improvements - #A-1

EXHIBIT B

28. RELOCATE SIGN

Contractor to relocate existing signs to new 3lb galvanized steel U-channel posts or 2"x2" 12-gauge galvanized steel square tube posts, as directed by the Engineer. Sign posts also requiring a lighting system shall be of the size required by the lighting system manufacturer. Existing signs shall be stockpiled in a manner to prevent damage to sign sheeting. Contractor shall inventory these signs by street name, location, and sign message and provide inventory to Engineer prior to removal. Install all signs 7'-0" from the base of the sign to ground elevation where sign is shown on the plan sheets. Any other relocated signs are to be installed at the same height as the original condition.

Relocated bus stop signs are required to be installed on a new 12-gauge galvanized steel square tube post at the size indicated in these specifications or on the plans, 7'-0" from the base of the sign to ground elevation, 2'-0" minimum from face of curb to signpost, and ahead of stop 2'-0" from concrete section in utility strip. If an existing bus stop sign is not present or the existing sign is not salvageable, a new sign shall be obtained from the Owner.

Any backfilling, compaction, concrete, brick work, or joint sealer required to remove the existing post hole is to be considered incidental to the relocation of the sign.

Relocate Sign payment will be made at the unit price per each to include all equipment, labor, new sign posts, materials and incidentals to furnish and install the sign post and install existing signs as indicated here in and shown on the plan sheets. The Contractor will be responsible for all costs to replace existing signs if damaged during removal or installation.

29. PERMANENT SIGNAGE

Furnish signs with messages as shown on the plans or as directed by the Engineer and that meet the requirements of Section 901 of the latest version of the *NCDOT Standard Specifications for Roads and Structures* and the *Manual on Uniform Traffic Control Devices (MUTCD)*. Conform to the message layout, size, and color as required by the plans or as directed by the Engineer. Use prismatic retroreflective sheeting that meets the minimum retro-reflectivity values found in the latest edition of the *MUTCD*.

Permanent signage shall be installed in accordance with the latest version of the *NCDOT Standard Specifications for Roads and Structures*, *NCDOT Roadway Standard Drawings*, and the *MUTCD*. Signs provided for pedestrian and school crossings and zones shall use the strong yellow-green coloring rather than the traditional yellow of warning signs. Prismatic sheeting shall be a micro-prismatic lens reflective sheeting, classified using ASTM D4956-04. Sheeting types to be used are ASTM Type III, IV, and VI-X.

GoTriangle Bus Stop Improvements - #A-1

EXHIBIT B

Permanent Signage shall be considered full compensation for all equipment, materials, labor, fabrication, footings, supports, hardware, and incidentals for work associated with the installation of new permanent traffic signage at locations as shown on the plans.

Contractor shall submit a sample sign type or detailed submittal for approval by the Engineer prior to ordering the sign.

Use 3lb galvanized steel U-channel sign posts or steel square tube posts, as directed by the Engineer, of sufficient length to permit the appropriate sign mounting height. New sign post installations and locations with bus stop security lighting systems shall be smooth wall or "Telespar Qwik-Punch" with knockouts square tube signs, or equivalent approved by the Owner All sign posts used shall meet the requirements of Section 1094 of the latest version of the NCDOT Standard Specification for Roads and Structures.

Permanent Signage payments will be made at the unit price per square foot or as otherwise indicated in the itemized proposal and will include, but is not limited to, signage fabrication and installation, including 3 lb. galvanized steel U-channel posts, square posts, bolts, fabrication, machine work and any incidentals required to install the traffic signage.

30. ADJUST UTILITY BOX/VAULT

Adjust Utility Box/Vault will be constructed to adjust the existing utility box/vault vertically using the appropriate materials so that it is flush with the proposed surface. The Contractor's attention is directed to Article 858-3 of the latest version of the *NCDOT Standard Specifications for Roads and Structures* for applicable construction methods.

Adjust Utility Box/Vault payment will be made per utility box/vault satisfactorily adjusted. Such price includes, but is not limited to, removal of a portion of the existing structure, materials, labor, equipment, coordination, and tools necessary to complete the work. Existing frames and covers are to be salvaged and reused in the adjustment. Any coordination with the owner of the utility is to be done by the contractor in accordance with this contract and is to be considered incidental to the contract.

31. ADJUST WATER METER

Adjust Water Meter will be constructed to adjust the existing water meter vertically using the appropriate materials so that it is flush with the proposed surface. The Contractor's attention is directed to Article 858-3 of the latest version of the *NCDOT Standard Specifications for Roads and Structures* for applicable construction methods.

Adjust Water Meter payment will be made per water meter satisfactorily adjusted. Such price includes, but is not limited to, removal of a portion of the existing structure, materials, labor, equipment, coordination, and tools necessary to complete the work. Existing frames and covers are to be salvaged and reused in the adjustment. Any

GoTriangle Bus Stop Improvements - #A-1

EXHIBIT B

coordination with the owner of the utility is to be done by the contractor in accordance with this contract and is to be considered incidental to the contract.

GoTriangle Bus Stop Improvements - #A-1

EXHIBIT B

32. ADJUST MANHOLE

Adjust Manhole will be completed in accordance to Section 858 of the latest version of the *NCDOT Standard Specifications for Roads and Structures*.

Adjust Manhole payment will be made at the unit price per each manhole satisfactorily adjusted or as otherwise indicated in the itemized proposal and will include the labor, materials, and all other miscellaneous items needed to complete the adjustment.

33. -" RCP, CLASS -

" RCP Class _ will be completed in accordance to Section 310 of the latest version of the *NCDOT Standard Specifications for Roads and Structures* at the size and class of pipe specified.

" RCP Class _ payment will be made at the unit price per the actual number of linear feet of pipe that has been incorporated into the completed and accepted work or as otherwise indicated in the itemized proposal and will include the labor, materials, foundation conditioning materials, any required geotextile fabric, subgrade materials, any required undercut excavation, and all other miscellaneous items needed to satisfactorily install the pipe.

34. -" HDPE

" HDPE will be completed in accordance to Section 310 of the latest version of the *NCDOT Standard Specifications for Roads and Structures* at the size and class of pipe specified.

" HDPE payment will be made at the unit price per the actual number of linear feet of pipe that has been incorporated into the completed and accepted work or as otherwise indicated in the itemized proposal and will include the labor, materials, foundation conditioning materials, any required geotextile fabric, subgrade materials, any required undercut excavation, and all other miscellaneous items needed to satisfactorily install the pipe.

35. FRAME WITH GRATE STD.

Frame with Grate Std. _ will be completed in accordance to Section 840 of the latest version of the *NCDOT Standard Specifications for Roads and Structures*.

Frame with Grate Std. _ payment will be made at the unit price per each assembly incorporated into the completed and accepted work or as otherwise indicated in the itemized proposal and will include the labor, materials, grates, any hoods, covers, or

GoTriangle Bus Stop Improvements - #A-1

EXHIBIT B

grates required per the standard detail, and all other miscellaneous items needed to install the assembly.

36. MASONRY DRAINAGE STRUCTURES

Masonry Drainage Structures will be completed in accordance to Section 840 of the latest version of the *NCDOT Standard Specifications for Roads and Structures*.

Masonry Drainage Structures will also include *Storm Inlet – Durham Std. 633.03 and Endwall* as specified on the plan.

Masonry Drainage Structures payment will be made at the unit price per each of the drainage structures constructed and approved or as otherwise indicated in the itemized proposal and will include the labor, materials, subgrade material, required steps and all other miscellaneous items needed to install the structure. No additional payment will be made for structures exceeding 5' in height unless otherwise noted by the engineer.

37. FLOWABLE FILL

Flowable Fill will be completed in accordance to NCDOT Special Provision SP03 R030.

Flowable Fill payment will be made at the unit price per cubic yard of flowable fill constructed and approved or as otherwise indicated in the itemized proposal and will include the labor, materials, subgrade material, required steps and all other miscellaneous items needed to install the flowable fill.

GoTriangle Bus Stop Improvements - #A-1

EXHIBIT B

38. CLASS - RIPRAP

Class - RipRap will be supplied and installed in accordance to Section 876 of the latest version of the *NCDOT Standard Specifications for Roads and Structures*.

Class - RipRap payment will be made at the unit price per ton of the class of riprap supplied, installed, and approved or as otherwise indicated in the itemized proposal and will include the labor, materials, and all other miscellaneous items needed to install the riprap.

39. GEOTEXTILE FABRIC

Geotextile Fabric will be supplied and installed in accordance to Section 876 of the latest version of the *NCDOT Standard Specifications for Roads and Structures* (see "Geotextile for Drainage").

Geotextile Fabric payment will be made at the unit price per square yard of geotextile fabric satisfactorily installed and approved or as otherwise indicated in the itemized proposal and will include the labor, materials, staples, pin, and all other miscellaneous items needed to install the geotextile fabric.

40. PLANT TREE

The height of the trees (measured from the crown of the roots to the tip of the top branch) shall not be less than the minimum size designated. Take caliber measurement six (6") inches above ground level up to and including four (4") inch caliber sizes and twelve (12") inches above the ground for larger sizes. The trunk of each tree shall be a single trunk growing from a single unmutilated crown of roots. No part of the trunk shall be conspicuously crooked as compared with normal trees of the same variety. The trunk shall be free from sunscald, frost cracks, or wounds resulting from abrasions, fire, or other causes. No pruning wounds shall be present having a diameter exceeding two inches and such wounds must show a vigorous bark on all edges. Plants shall not be pruned prior to delivery.

All woody trees and shrubs shall be balled and burlapped or grown in containers; bare-rooted trees or shrubs shall not be permitted.

For balled and burlapped trees and shrubs, burlap shall be 100% cloth burlap and must be moved with the root systems as solid units with balls of earth firmly wrapped with untreated eight (8) ounce burlap, firmly held in place by a stout cord. No poly-burlap shall be allowed on plant materials. Any use of wire cages shall be approved in writing by the Owner. Wire must not be galvanized or aluminum wire. Any balled and burlapped trees and shrubs delivered to the site with materials other than 100% cloth burlap shall automatically be rejected and the installer shall remove them from the site within twenty-four (24) hours.

GoTriangle Bus Stop Improvements - #A-1

EXHIBIT B

- A. The diameter and depth of the balls of earth must be sufficient to encompass the fibrous root feeding system necessary for the healthy development of the plant.
- B. No plant shall be accepted when the ball of earth surrounding its roots has been badly cracked or broken preparatory to or during the process of planting or after the burlap, staves, ropes, or platform required in connection with its transplanting have been removed.
- C. The plants and root balls shall remain intact during all operations.
- D. All plants that cannot be planted at once shall be heeled in by setting on the ground, covering the balls with soil, and watering them to maintain moisture level.

The Owner retains the right to observe trees and shrubs further for size and condition of balls and root systems, insects, injuries, and latent defects and to reject unsatisfactory or defective material at any time during progress of work. Remove rejected trees or shrubs immediately from the project site.

The Contractor shall be responsible for furnishing their own supply of water to the site at no extra cost. Any plant material injured or damaged due to the lack of water, or the use of too much water, shall be the Contractor's responsibility to correct. Water shall be free from impurities injurious to vegetation.

The Contractor shall submit a schedule for planting to the Owner for approval to ensure that the Schedule of Work will minimize the potential for plant damage and to insure timely installation of all material.

Do not prune trees and shrubs before delivery, except as approved by Owner. Protect bark, branches, and root systems from sun scald, drying, sweating, whipping, and other handling and tying damage. Do not bend or bind-tie trees or shrubs in such a manner as to destroy their natural shape. Provide protective covering of exterior plants during delivery. Do not drop exterior plants during delivery.

Planting restrictions shall be as follows:

1. Shrubs: Planting shall only occur between October 1 and April 31.
2. Non-woody plantings: Planting shall be installed during the commonly recognized planting times consistent with the specified plant species.
3. Coordinate planting periods with maintenance periods to provide required maintenance from date of Substantial Completion.
4. If overall project Substantial Completion occurs prior of the specified planting dates, planting shall not be installed until specified planting dates.

GoTriangle Bus Stop Improvements - #A-1

EXHIBIT B

Following completion of all plant material installation, the Contractor shall request the City in writing for a formal inspection of the planting.

If a substantial number of plants are sickly or dead at the time of final inspection, acceptance will not be granted, and the Contractor's responsibility for maintenance of all plants shall be extended until replacements are made. All dead and unsatisfactory plants shall be promptly removed from the project. Replacements shall conform in all respects to the specifications for new plants and shall be planted in the same manner and location. The Contractor shall maintain replacements during the Maintenance Period.

The Contractor is to provide complete Maintenance Service by skilled employees of landscape installer. Maintain as required by these specifications. The Contractor shall follow the following Maintenance period provisions:

1. Maintenance shall begin immediately after each plant is planted and shall continue through both Substantial Completion and the minimum twelve (12) month maintenance period as specified, herein.
2. After installation and before Substantial Completion, remove nursery stakes, tie tape, labels, wire, burlap, and other debris from plant material, plantings, and Project site. Remove tree stabilization materials at the end of the maintenance period, or as approved by Owner. Nursery tags with species name shall remain until the end of the maintenance period.
3. During the maintenance period, any decline in the condition of planted material shall require the Contractor to take immediate action to identify potential problems and undertake corrective measures.

Following planting and anytime during the Maintenance Period, plantings that die or show obvious decline or loss of more than ten (10%) percent of healthy growth, shall be removed and replaced at once unless designated otherwise in writing by the City. Replacements shall conform in all respects to the specifications for new plants and shall be planted in the same manner and location.

The Contractor is to warrant all installed exterior plants for the warranty period indicated against defects including death and unsatisfactory growth.

The warranty period for all plants shall be twelve (12) months from date of Substantial Completion, unless plantings are installed during their required planting date following Substantial Completion. End of Warranty period will be tied to twelve (12) months from Substantial Completion.

GoTriangle Bus Stop Improvements - #A-1

EXHIBIT B

Plants shall be alive and in satisfactory growth at the end of the Warranty Period. Plants that die or show obvious decline or loss of healthy growth during the Warranty Period shall be removed and replaced, unless designated otherwise by the Owner. Each plant shall show at least ninety- five (95%) percent healthy growth and shall have the natural character of a plant of its species in accordance with the American Nurserymen's Association Standards. Dead or unsatisfactory plants shall be replaced only during the specified planting season.

All replacements shall be plants of the same species, variety, and size specified in the Plant Schedule and all material, installation, and incidental costs shall be borne by the Contractor, except for possible replacements due to vandalism or neglect on the part of others.

Plant Tree payment will be made at the unit price per each tree planted and accepted by the Owner and will include all equipment, labor, tree, materials, water, maintenance required during the warranty period, and incidentals to install and maintain the tree as directed. Watering will be considered incidental to this item. Any tree removed during demolition that was not marked for removal on the plans or by the Engineer should be replaced by a tree of the same species at no additional cost to the City.

41. SURVEY CONSTRUCTION STAKES

Survey CADD files will be provided to the Contractor at their request for use in staking the construction layout, right-of-way or easements on proposed improvements. The Contractor will be responsible for any staking and this work will be considered incidental to the contract.

42. MATERIALS SAMPLING & TESTING

The Contractor is responsible for the quality control of his/her work including but not limited to compaction of subgrade, compaction of aggregate base course, strength of concrete, etc. The Owner may use an independent testing laboratory to test areas found to be noncompliant. The Contractor will be responsible for all repair and replacement costs including retesting costs for areas found to be noncompliant.

GoTriangle Bus Stop Improvements - #A-1

EXHIBIT B

43. CLEARING AND GRUBBING

The Contractor shall furnish all labor, equipment, materials, tools, etc. and shall perform all clearing and grubbing of trees, down timber, logs, snags, brush undergrowth, heavy growth of grass or weeds, debris, and rubbish, etc. All such material shall be disposed of by burning (when permitted), suitable removal from the site, or other means acceptable to the Engineer.

The width of clearing for the project shall be limited to the right of way and/or temporary and permanent easements as noted on the drawings. The entire width of the permanent easement is to be cleared unless otherwise indicated by clearing limits noted on the drawings. Clearing and grubbing shall be conducted in a manner to prevent damage to vegetation that is intended to remain growing and also to prevent damage to adjacent property.

The Engineer will designate all areas of growth or individual trees inside the clearing limits, which are to be preserved due to their desirability. The trees to be preserved will be shown in the Contract Documents or designated by the Engineer.

All spoil materials that are removed by clearing and grubbing operations shall be adequately disposed of, removed from the site or burned if permitted by the appropriate authorities. The contractor shall be responsible for controlling fires in compliance with all Federal, State or local laws.

All work performed under this section shall cause a minimum of erosion and sediment pollution as outlined in this contract. Installation of temporary or permanent erosion control measures shall occur immediately after clearing and grubbing operations have begun or as directed by the Engineer.

No direct payment will be made for this work, as the cost of this work is being paid for at the contract lump sum price for *Demolition*.

GoTriangle Bus Stop Improvements - #A-1

EXHIBIT B

44. SHOULDER AND FILL SLOPE MATERIAL (LUMP SUM EARTHWORK)

Perform the required shoulder and slope construction for this project in accordance with the applicable requirements of Section 226 of the Standard Specifications except as follows:

- Construct the top 6 inches of shoulder and fill slopes with soils capable of supporting vegetation.
- Provide soil with a P.I. greater than 6 and less than 25 and with a pH ranging from 5.5 to 6.8. Remove stones and other foreign material 2 inches or larger in diameter. All soil is subject to test and acceptance or rejection by the Engineer.
- Obtain material from approved borrow site. The Contractor is responsible for any erosion control requirements of off-site borrow sites.

No direct payment will be made for this work, as the cost of this work will be considered to be covered under the contract lump sum price for *Earthwork*.

45. BURNING RESTRICTIONS

Open burning is not permitted on any portion of the limits established for this project. Do not burn the clearing, grubbing or demolition debris designated for disposal and generated from the project at locations within the project limits, off the project limits or at any waste or borrow sites in this county. Dispose of the clearing, grubbing and demolition debris by means other than burning, according to state or local rules and regulations.

GoTriangle Bus Stop Improvements - #A-1

EXHIBIT B

46. COORDINATION WITH UTILITY COMPANIES

Utilities as shown on the plans are intended to represent general locations only. It shall be the responsibility of the Contractor, prior to construction, to contact appropriate utility owners and precisely locate utilities that could be affected by the proposed construction. If the utility belongs to the Owner, the Contractor shall dig sample holes to uncover the utility. The digging of sample holes shall be coordinated with the Engineer who will determine the number of such holes and will schedule the Owner to locate utility vertical and horizontal locations. There is no line item to pay for digging work. Work is considered incidental to other pay items.

The Contractor shall be responsible for repair of any damage to the utility as well as any other damage may be caused due to the disturbance of the Utility. The Contractor will not be permitted to submit any claims for delays caused by utility relocation and proposed utility construction.

The Contractor shall be responsible for coordinating concurrent construction directly with utility owner representatives. Coordination efforts and concurrent construction conflicts will be addressed and discussed during the pre-construction meeting. The Owner, at the time of pre-construction conference, will provide names, addresses and telephone numbers of private utility owner representatives.

All underground utilities may not have been identified. The Contractor shall call North Carolina One Call to identify underground utilities before starting any digging and/or excavation operation.

The Contractor shall be responsible for field verifying heights and locations of power lines and will be required to maintain the distance from the power lines in accordance with local, State and Federal Safety regulations.

GoTriangle Bus Stop Improvements - #A-1

EXHIBIT B

47. NCDOT ERRATA

Revise the *NCDOT 2024 Standard Specifications* as follows:

END OF SECTION